

USER MANUAL

VOLANT PRO 8KW, 10KW SOLAR INVERTER / CHARGER



Version: 1.0

Contents

1. About This Manual	1
1.1 Purpose	1
1.2 Scope.....	1
2. Safety Instructions	1
3. Introduction	1
3.1 Features.....	1
3.2 Basic System Architecture	2
3.3 Product Overview	3
4. Installation.....	4
4.1 Unpacking And Inspection	4
4.2 Preparation	4
4.3 Mounting The Unit.....	5
4.4 Battery Connection.....	5
4.5 AC Input/output Connection.....	7
4.6 PV Connection	8
4.7 Final Assembly	12
4.8 RS232 Communication Connection.....	12
4.9 Wi-Fi Connection(Optional)	13
4.10 Dry Contact Signal	13
5. Operation.....	14
5.1 Power ON/OFF	14
5.2 Operation And Display Panel.....	14
5.3 LCD Display Icons.....	15
5.4 LCD Setting.....	20
5.5 LCD Display	33
6. Parallel Installation Guide.....	41
6.1 Parallel Operation Cable	41
6.2 Matters Needing Attention In Single-phase Parallel Operation.....	42
6.3 Single-phase Parallel Operation Cable Connection	42
6.4 Matters Needing Attention In Three-phase Parallel Operation	46
6.5 Three-phase Parallel Operation Cable Connection.....	46
6.6 Matter need attention of the parallel installation	53
7. Faults Code	56
8. Warning Code	56
9. Parallel Faults Code.....	58
10. Trouble Shooting.....	59
11. Specifications	62
11.1 Line Mode Specifications	62
11.2 Inverter Mode Specifications.....	63
11.3 Charge Mode Specifications	64
11.4 General Specifications.....	65
12. Installation Dimension Drawing	65

1. About This Manual

1.1 Purpose

This manual describes the assembly, installation, operation and troubleshooting of this unit. Please read this manual carefully before installations and operations. Keep this manual for future reference.

1.2 Scope

This manual provides safety and installation guidelines as well as information on tools and wiring.

2. Safety Instructions

⚠ WARNING: This chapter contains important safety and operating instructions. Read and keep this manual for future reference.

1. before using the unit, read all instructions and cautionary markings on the unit, the batteries and all appropriate sections of this manual.
2. **CAUTION** -- To reduce the risk of injury, please charge deep-cycle lead acid type rechargeable batteries only. Charge other type of batteries may burst and cause personal injury
3. Do not disassemble the unit. Take it to a qualified service center when service or repair is required. Incorrect re-assembly may result in a risk of electric shock or fire.
4. To reduce risk of electric shock, disconnect all wire before attempting any maintenance or cleaning. Turning off the unit will not reduce this risk.
5. **CAUTION** – Only qualified personnel can install this device with battery.
6. **NEVER** charge a frozen battery.
7. For optimum operation of this inverter/charger, please follow required spec to select appropriate cable size. It's very important to correctly operate this inverter/charger.
8. Be very cautious when working with metal tools on or around batteries. A potential risk exists to drop a tool to spark or short circuit batteries or other electrical parts and could cause an explosion.
9. Please strictly follow installation procedure when you want to disconnect AC or DC terminals. Please refer to INSTALLATION section of this manual for the details.
10. Fuses are provided as over-current protection for the battery supply.
11. **GROUNDING INSTRUCTIONS** -This inverter/charger should be connected to a permanent grounded wiring system. Be sure to comply with local requirements and regulation to install this inverter.
12. **NEVER** cause AC output and DC input short circuited. Do NOT connect to the mains when DC input short circuits.
13. **Warning!!** Only qualified service persons are able to service this device. If errors still persist after following troubleshooting table, please send this inverter/charger back to local dealer or service center for maintenance.
14. **WARNING:** Because this inverter is non-isolated, only three types of PV modules are acceptable: single crystalline, poly crystalline with class A-rated and CIGS modules. To avoid any malfunction, do not connect any PV modules with possible current leakage to the inverter. For example, grounded PV modules will cause current leakage to the inverter. When using CIGS modules, please be sure NO grounding.
15. **CAUTION:** It's required to use PV junction box with surge protection. Otherwise, it will cause damage on inverter when lightning occurs on PV modules.

3. Introduction

This is a multi-function inverter, combining functions of inverter, solar charger and battery charger to offer uninterruptible power support in a single package. The comprehensive LCD display offers user-configurable and easy-accessible button operations such as battery charging current, AC or solar charging priority, and acceptable input voltage based on different applications.

3.1 Features

1. Off grid inverter
2. Pure sine wave inverter
3. External WIFI devices (APP is required)
4. Communication ports with BMS (RS485, CAN)
5. Support the selection of wide and narrow range of AC input
6. Configurable AC/Solar charger priority via LCD control panel

7. Configurable battery charging current based on applications via LCD control panel
8. Compatible to utility mains or generator power
9. Auto restart while AC is recovering
10. Overload / Over temperature / short circuit protection
11. Cold start function

3.2 Basic System Architecture

The following illustration shows basic application for this unit. It also required the following devices to have a complete running system:

- Generator or Utility mains.
- PV modules

Consult with your system integrator for other possible system architectures depending on your requirements. This inverter can power various appliances in home or office environment, including motor-type appliances such as tube light, fan, refrigerator and air conditioners.

NOTE: The following picture is only a schematic diagram of the equipment .If the actual chassis does not conform to the schematic due to a structural upgrade, it is subject to prior notice.

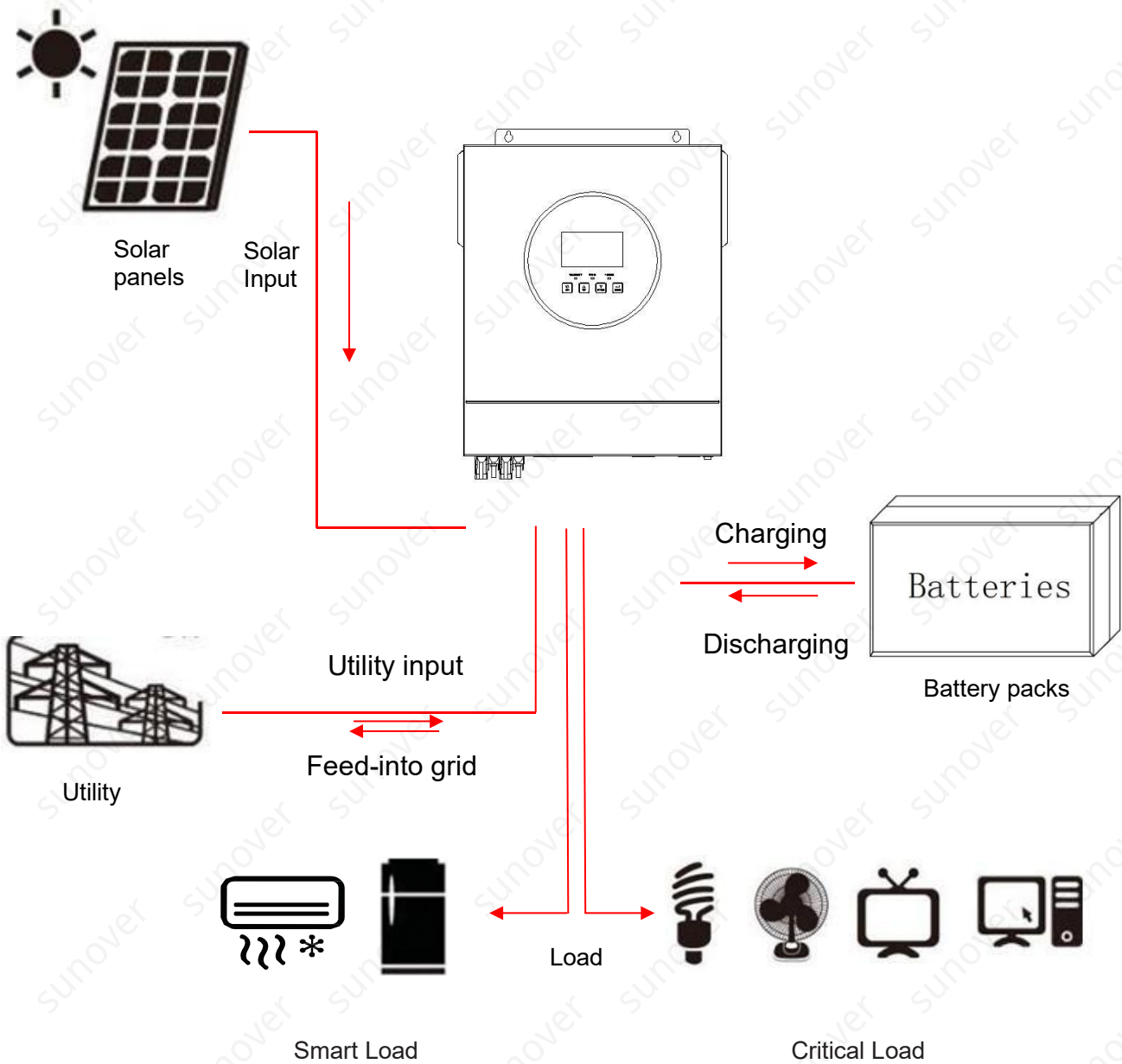
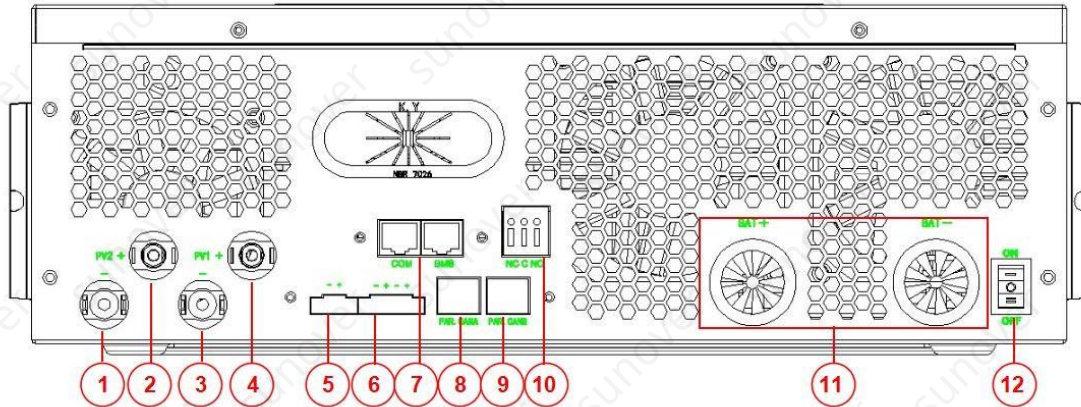

Figure 1 Off grid Power System

3.3 Product Overview

NOTE: The following picture is only a schematic diagram of the equipment .If the actual chassis does not conform to the schematic due to a structural upgrade, it is subject to prior notice.



- | | |
|-----------------------------|---------------------------|
| 1. PV2 negative connector | 7. COMM port and BMS port |
| 2. PV2 positive connector | 8. PAR.CANA |
| 3. PV1 negative connector | 9. PAR.CANB |
| 4. PV1 positive connector | 10. Generator dry contact |
| 5. CT port | 11. Battery terminals |
| 6. PAR Current sharing port | 12. Power on/off switch |

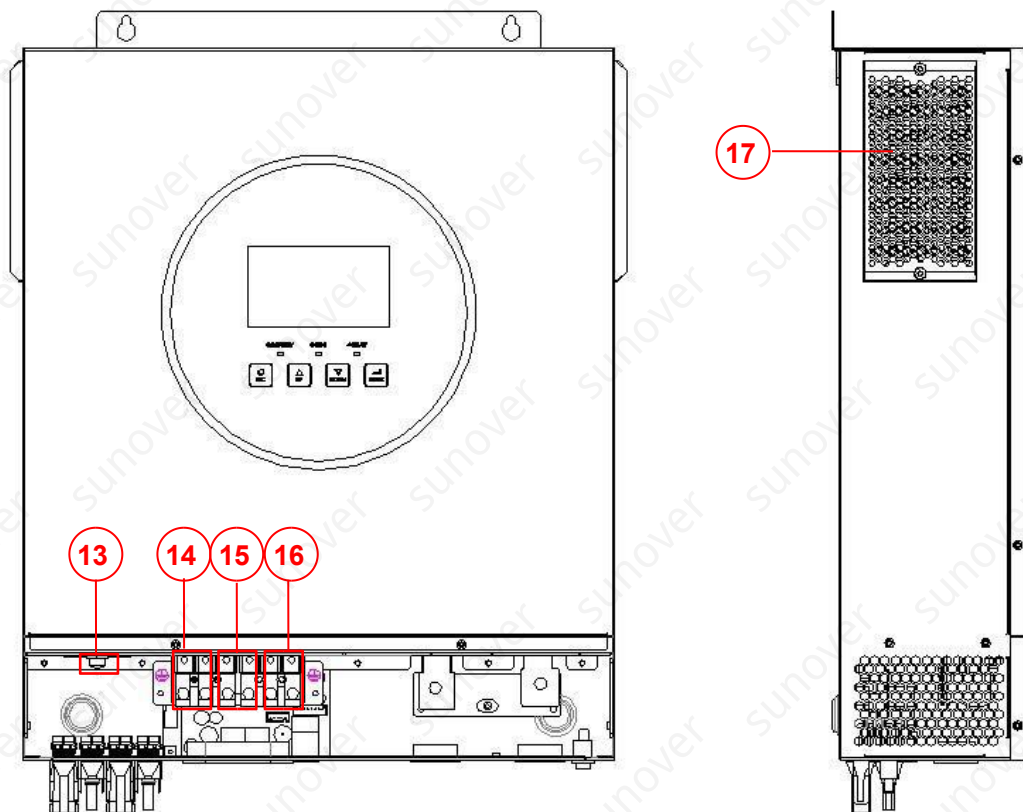

- | | |
|--------------|------------------------------|
| 13. Breaker | 16. AC OUTPUT(Second output) |
| 14. AC INPUT | 17. Dust Cover |
| 15. MASTER | |

Note: RS485, CAN communication share the same port ,so it can't be used at the same time.

COMM: RS232	1: RXD, 2: TXD 4: +VCC ,8: GND
BMS: RS485 CAN	1: 485-B , 2: 485-A 4: CAN-H , 5: CAN-L

Communication port definition :

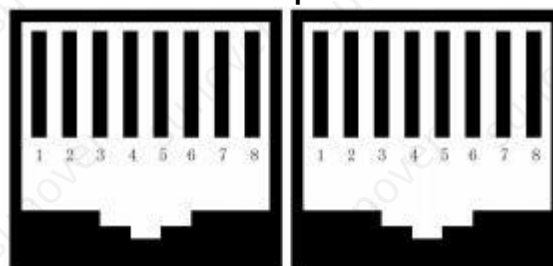

COMM

BMS

4. Installation

4.1 Unpacking And Inspection

Before installation, please inspect the unit. Be sure that nothing inside the package is damaged. You should have received the following items inside of package:

The inverter x1

User manual x 1

Parallel communication cable x 1(No parallel machine ,No need)

Current sharing cable x 1 (No parallel machine ,No need) PV

connectors x 2 sets

4.2 Preparation

Before connecting all wire, please take off bottom cover by removing two screws.

NOTE: The following picture is only a schematic diagram of the equipment .If the actual chassis does not conform to the schematic due to a structural upgrade, it is subject to prior notice.

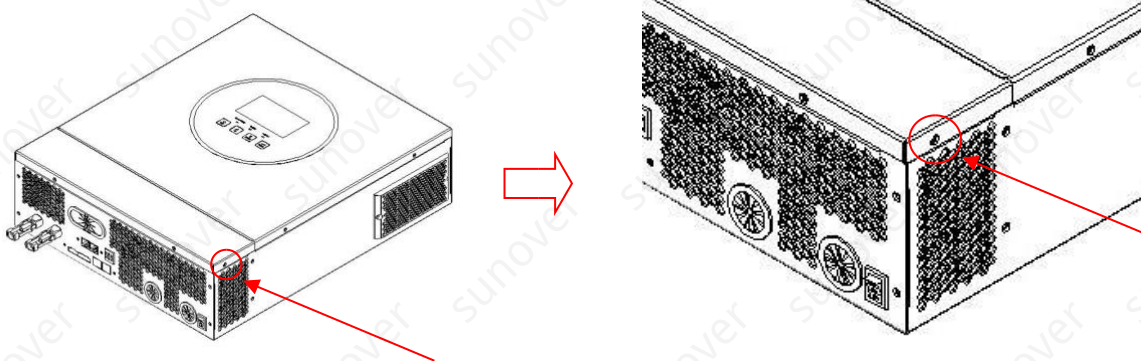

4.3 Mounting The Unit

Consider the following points before selecting where to install:

1. Do not mount the inverter on flammable construction materials.
2. Mount on a solid surface
3. Install this inverter at eye level in order to allow the LCD display to be read at all times.
4. The ambient temperature should be between 10°C and 50°C to ensure optimal operation.
5. The recommended installation position is to be adhered to the wall vertically.
6. Be sure to keep other objects and surfaces as shown in the right diagram to guarantee sufficient heat dissipation and to have enough space for removing wires.

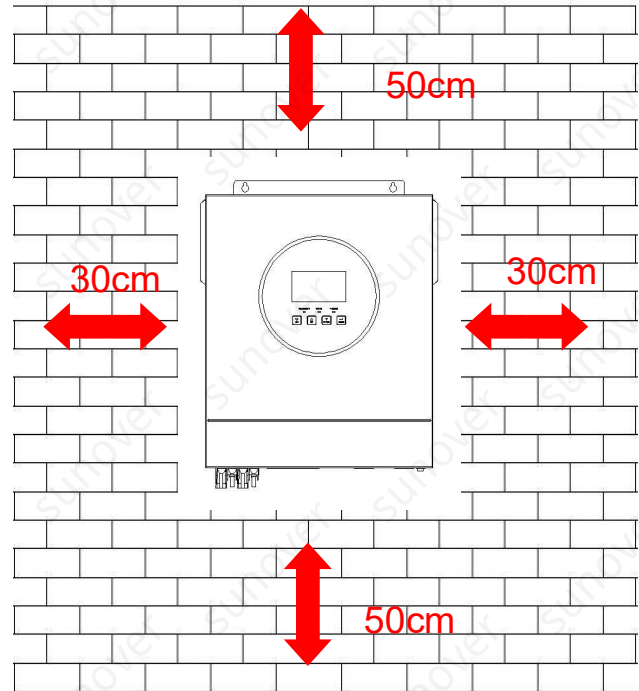

NOTE: The following picture is only a schematic diagram of the equipment .If the actual chassis does not conform to the schematic due to a structural

WARNING:SUITABLE FOR MOUNTING ON CONCRETE OR OTHER NON-COMBUSTIBLE SURFACE ONLY.

Install the unit by screwing four screws. It's recommended to use M4 or M5 screws.

NOTE: The following picture is only a schematic diagram of the equipment .If the actual chassis does not conform to the schematic due to a structural upgrade, it is subject to prior notice.

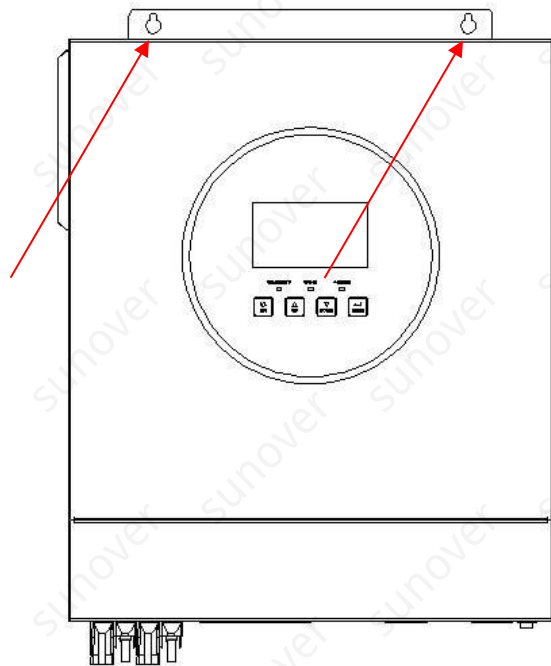

4.4 Battery Connection

CAUTION: For safety operation and regulation compliance, it's requested to install a separate DC overcurrent protector or disconnect device between battery and inverter. It may not be requested to have a disconnect device in some applications, however, it's still requested to have over-current protection installed.

Please refer to typical amperage in below table as required fuse or breaker size.

WARNING! All wiring must be performed by a qualified personnel.

WARNING! It's very important for system safety and efficient operation to use appropriate cable for battery connection. To reduce risk of injury, please use the proper recommended cable and terminal size as below

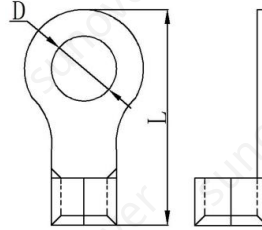

Recommended battery cable and terminal size: Ring terminal:

Model	Typical Amperage	Battery capacity	Wire Size	Cable mm ²	Ring Terminal		Torque value
					Dimensions		
					D (mm)	L (mm)	
10KW	208A	250AH	1*3/0AWG	85	8.4	54	5Nm

Please follow below steps to implement battery connection:

1. Assemble battery ring terminal based on recommended battery cable and terminal size.
2. Fix two cable glands into positive and negative terminals.

48VDC battery connection diagram

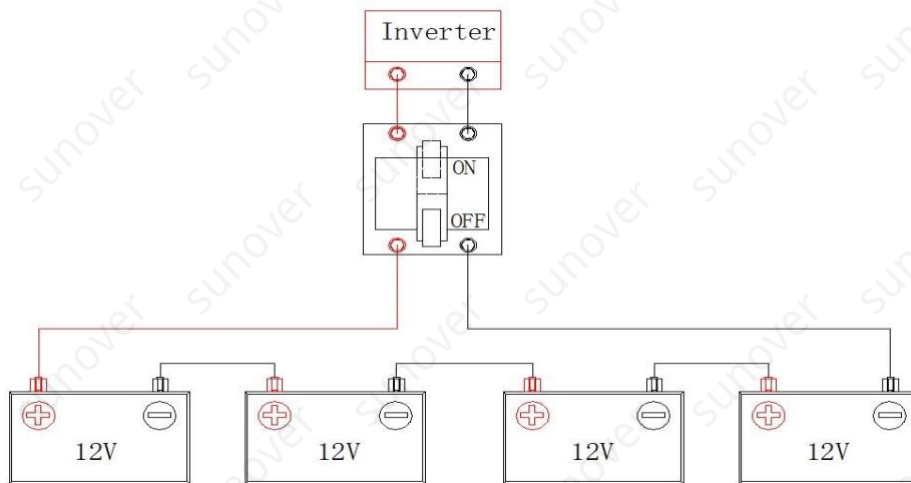

3. Insert the ring terminal of battery cable flatly into battery connector of inverter and make sure the nuts are tightened with torque of 5Nm. Make sure polarity at both the battery and the inverter/charge is correctly connected and ring terminals are tightly screwed to the battery terminals.

NOTE: The following picture is only a schematic diagram of the equipment .If the actual chassis does not conform to the schematic due to a structural upgrade, it is subject to prior notice.

WARNING: Shock Hazard

Installation must be performed with care due to high battery voltage in series

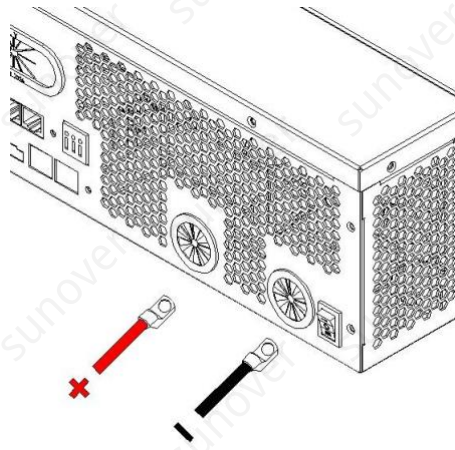

CAUTION!! Do not place anything between the flat part of the inverter terminal and the ring terminal. Otherwise, overheating may occur.

CAUTION!! Do not apply anti-oxidant substance on the terminals before terminals are connected tightly.
CAUTION!! Before making the final DC connection be sure positive (+) must be connected to positive (+) and negative (-) must be connected to negative(-).

4.5 AC Input/output Connection

CAUTION!! Before connecting to AC input power source, please install a separate AC breaker between inverter and AC input power source. This will ensure the inverter can be securely disconnected during.

maintenance and fully protected from over current of AC input. The recommended spec of AC breaker is 70A.

CAUTION!! Please refer to the input and output screen on the machine before wiring, make sure correct wiring.

CAUTION!! High touch current, earth connection essential before connection supply.

WARNING! All wiring must be performed by a qualified personnel.

WARNING! It's very important for system safety and efficient operation to use appropriate cable for AC input connection. To reduce risk of injury, please use the proper recommended cable size as below.

Suggested cable requirement for AC wires

Model	Gauge	Torque Value
10KW	8AWG	1.4~ 1.6Nm

Please follow below steps to implement AC input/output connection:

1. Before making AC input/output connection, be sure to protector disconnected first.
2. Remove insulation sleeve 10mm for six conductors. And shorten phase L and neutral conductor N 3 mm.
3. Fix two cable glands into input and output sides.
4. Insert AC input wires according to polarities indicated on terminal block and tighten the terminal screws. Be sure to connect PE protective conductor (⊕) first.

⊕ → **Ground (yellow-green)**

L → **LINE (brown or black)** N → **Neutral (blue)**

NOTE: The following picture is only a schematic diagram of the equipment .If the actual chassis does not conform to the schematic due to a structural upgrade, it is subject to prior notice.

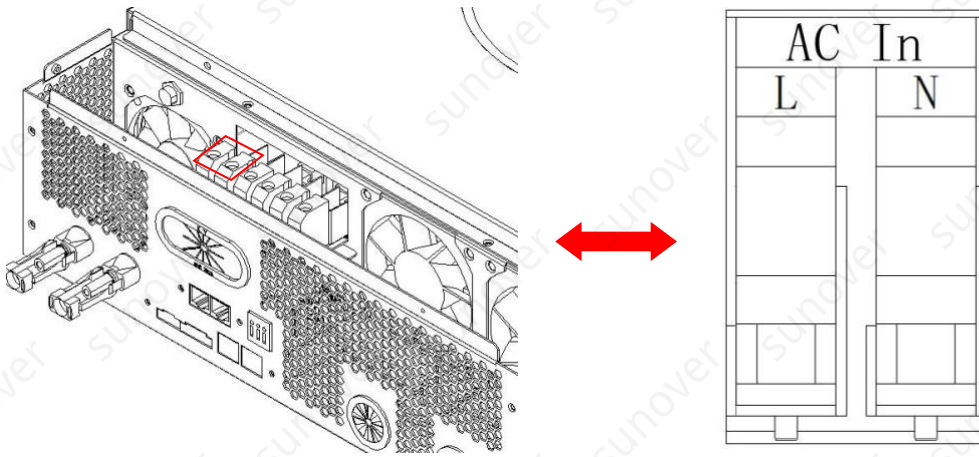

WARNING:

Be sure that AC power source is disconnected before connect wire to the unit.

This inverter is equipped with dual-output. There are four terminals (Master: L/N, AC OUTPUT: L/N [second output]) available on output port. It's set up through LCD program 12 control the second output. Refer to "LCD setting" section for the details.

5. Then, insert AC output wires according to polarities indicated on terminal block and tighten terminal screws.

Be sure to connect PE protective conductor (⊕) first.

⊕ → **Ground (yellow-green)**

L → **LINE (brown or black)**

N → **Neutral (blue)**

NOTE: The following picture is only a schematic diagram of the equipment. If the actual chassis does not conform to the schematic due to a structural upgrade, it is subject to prior notice.

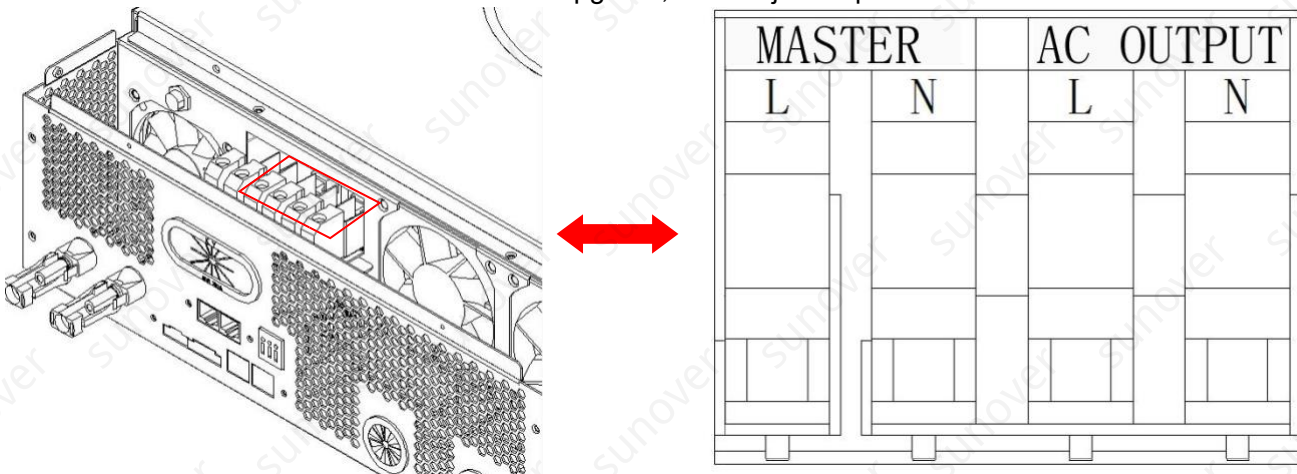

6. Make sure the wires are securely connected.

CAUTION: Important

Be sure to connect AC wires with correct polarity. If L and N wires are connected reversely, it may cause utility short-circuited when these inverters are worked in parallel operation.

CAUTION: Appliances such as air conditioner requires at least 2~3 minutes to restart because it's required to have enough time to balance refrigerant gas inside of circuits. If a power shortage occurs and recovers in a short time, it will cause damage to your connected appliances. To prevent this kind of damage, please check manufacturer of air conditioner if it's equipped with time-delay function before installation.

Otherwise, this inverter/charger will be trigger overload fault and cut off output to protect your appliance but sometimes it still causes internal damage to the air conditioner.

4.6 PV Connection

CAUTION: Before connecting to PV modules, please install separately DC circuit breakers between inverter and PV modules.

CAUTION: It is forbidden for inverter to share the same solar panel group.

NOTE1: Please use 600Vdc/30A circuit breaker.

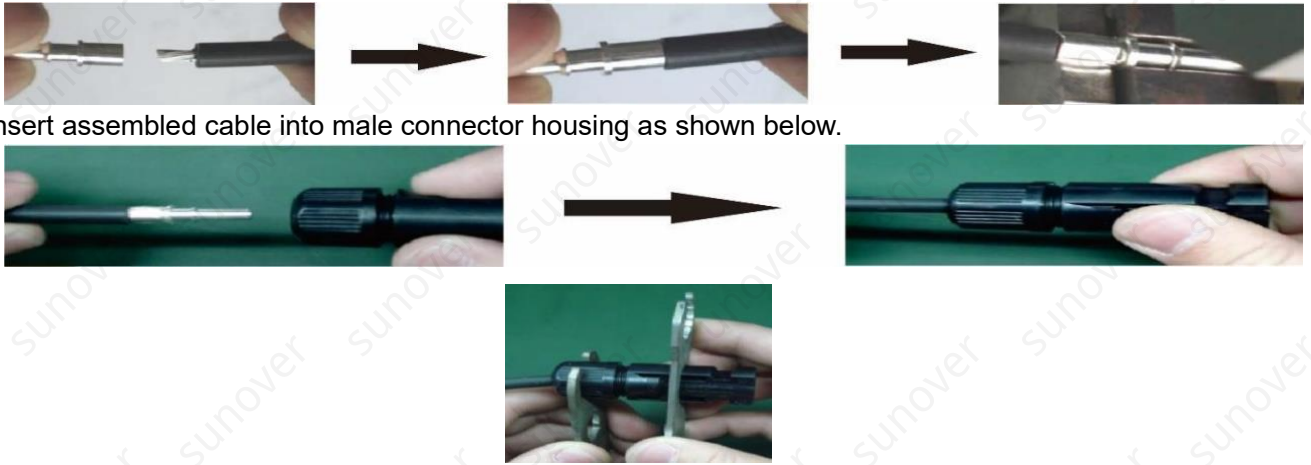

Insert assembled cable into male connector housing as shown below.

Step 4: Check correct polarity of connection cable from PV modules and PV input connectors. Then, connect positive pole (+) of connection cable to positive pole (+) of PV input connector. Connect negative pole (-) of connection cable to negative pole (-) of PV input connector.

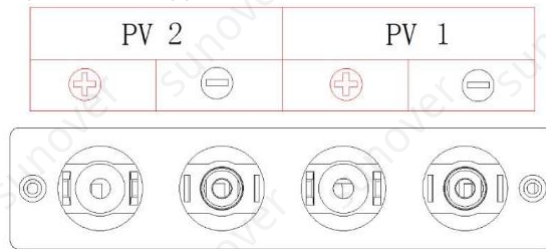

WARNING! For safety and efficiency, it's very important to use appropriate cables for PV module connection. To reduce risk of injury, please use the proper cable size as recommended below.

Model	Cable (mm ²)	AWG	Torque value(max)
10KW	4	12	1.2~1.6Nm

CAUTION: Never directly touch the terminals of inverter. It might cause lethal electric shock. **NOTE:** The following picture is only a schematic diagram of the equipment. If the actual chassis does not conform to the schematic due to a structural upgrade, it is subject to prior notice.

PV2 Connection

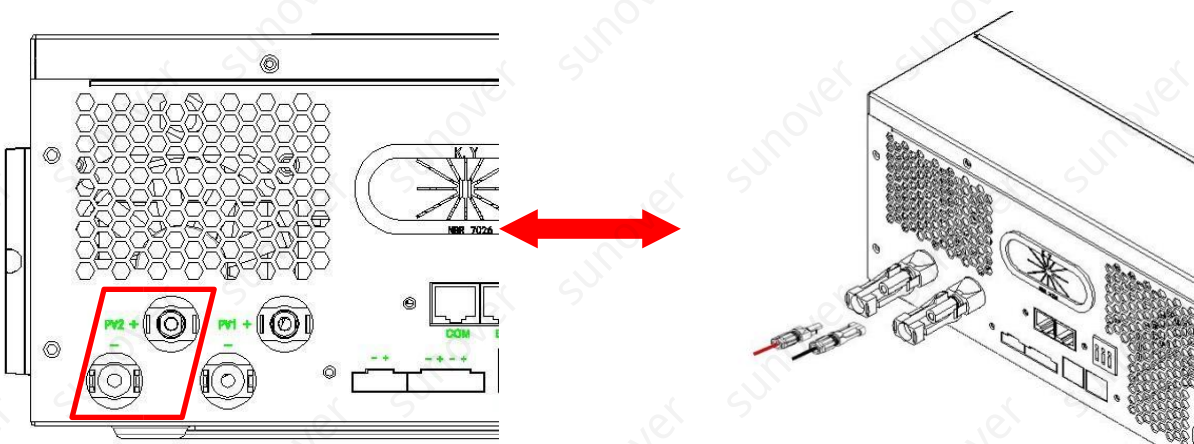

PV1 Connection

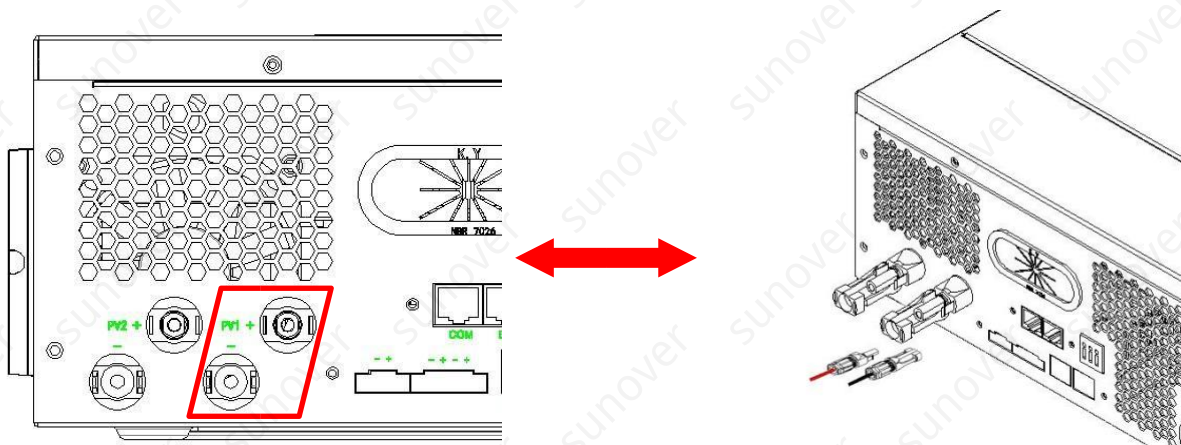

Recommended Panel Configuration

When selecting proper PV modules, please be sure to consider the following parameters:

1. Open circuit Voltage (Voc) of PV modules not to exceed maximum PV array open circuit voltage of the inverter.
2. Open circuit Voltage (Voc) of PV modules should be higher than the start-up voltage.

INVERTER MODEL	10KW
Max. PV Array Power	5000*2
Max. PV Array Open Circuit Voltage	500Vdc
PV Array MPPT Voltage Range	60Vdc~450Vdc

Recommended solar panel configuration 1:

Solar Panel Spec. (reference) - 250Wp - Vmp: 30.7Vdc - Imp: 8.3A - Voc: 37.7Vdc - Isc: 8.4A	SOLAR INPUT 1	SOLAR INPUT 2	Q'ty of panels	Total Input Power
	Min. in series: 6 pcs, per input Max. in series: 12 pcs, per input			
	6pcs in series	X	6pcs	1500W
	X	6pcs in series	6pcs	1500W
	6pcs in series	6pcs in series	12pcs	3000W
	6pcs in series, 2 strings	X	12pcs	3000W
	X	6pcs in series, 2 strings	12pcs	3000W
	8pcs in series, 2 strings	X	16pcs	4000W
	X	8pcs in series, 2strings	16pcs	4000W
	10pcs in series, 1 string	10pcs in series, 1 string	20pcs	5000W
	12pcs in series, 1 string	12pcs in series, 1 string	24pcs	6000W

6pcs in series, 2 strings	6pcs in series, 2 strings	24pcs	6000W
8pcs in series, 2 strings	8pcs in series, 2 strings	32pcs	8000W
9pcs in series, 2 strings	9pcs in series, 2 strings	36pcs	9000W
10pcs in series, 2 strings	10pcs in series, 2 strings	40pcs	10000W

Recommended solar panel configuration 2:

Solar Panel Spec. (reference) - 550Wp - Vmp:41.96Vdc - Imp: 13.11A - Voc: 49.9Vdc - Isc: 14A	SOLAR INPUT 1	SOLAR INPUT 2	Q'ty of panels	Total Input Power
	Min. in series: 4 pcs, per input Max. in series: 8 pcs, per input			
	4pcs in series	X	4pcs	2200W
	X	4pcs in series	4pcs	2200W
	8pcs in series	X	8pcs	4400W
	X	8pcs in series	8pcs	4400W
	6pcs in series, 1 string	6pcs in series, 1 string	12pcs	6600W
	7pcs in series, 1 string	7pcs in series, 1 string	14pcs	7700W
	8pcs in series, 1 string	8pcs in series, 1 string	16pcs	8800W

4.7 Final Assembly

After connecting all wiring, re-connect three cables and then put bottom cover back by screwing two screws as shown below.

NOTE: The following picture is only a schematic diagram of the equipment. If the actual chassis does not conform to the schematic due to a structural upgrade, it is subject to prior notice.

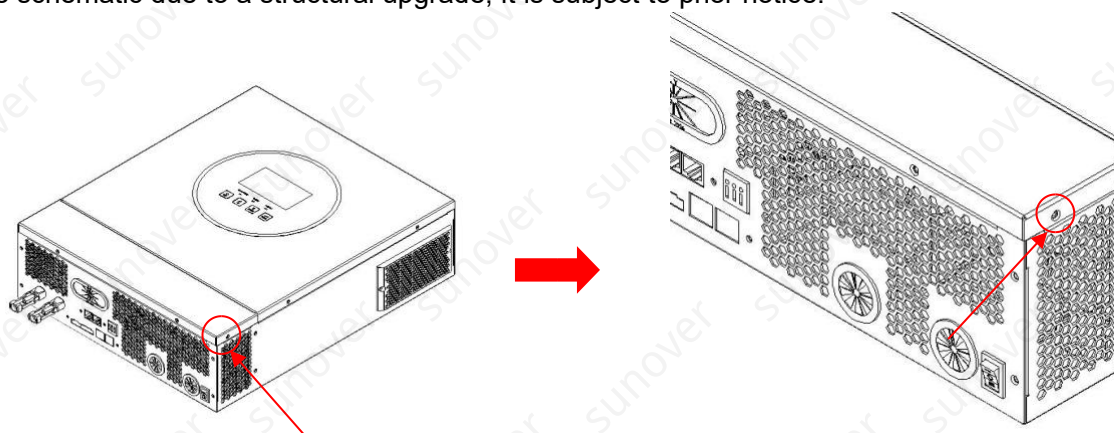

4.8 RS232 Communication Connection

Please download software "Watch Power" from the official website. When the inverter is connected to the computer, the following interface will be displayed. **Note:** The following dates are for reference only.

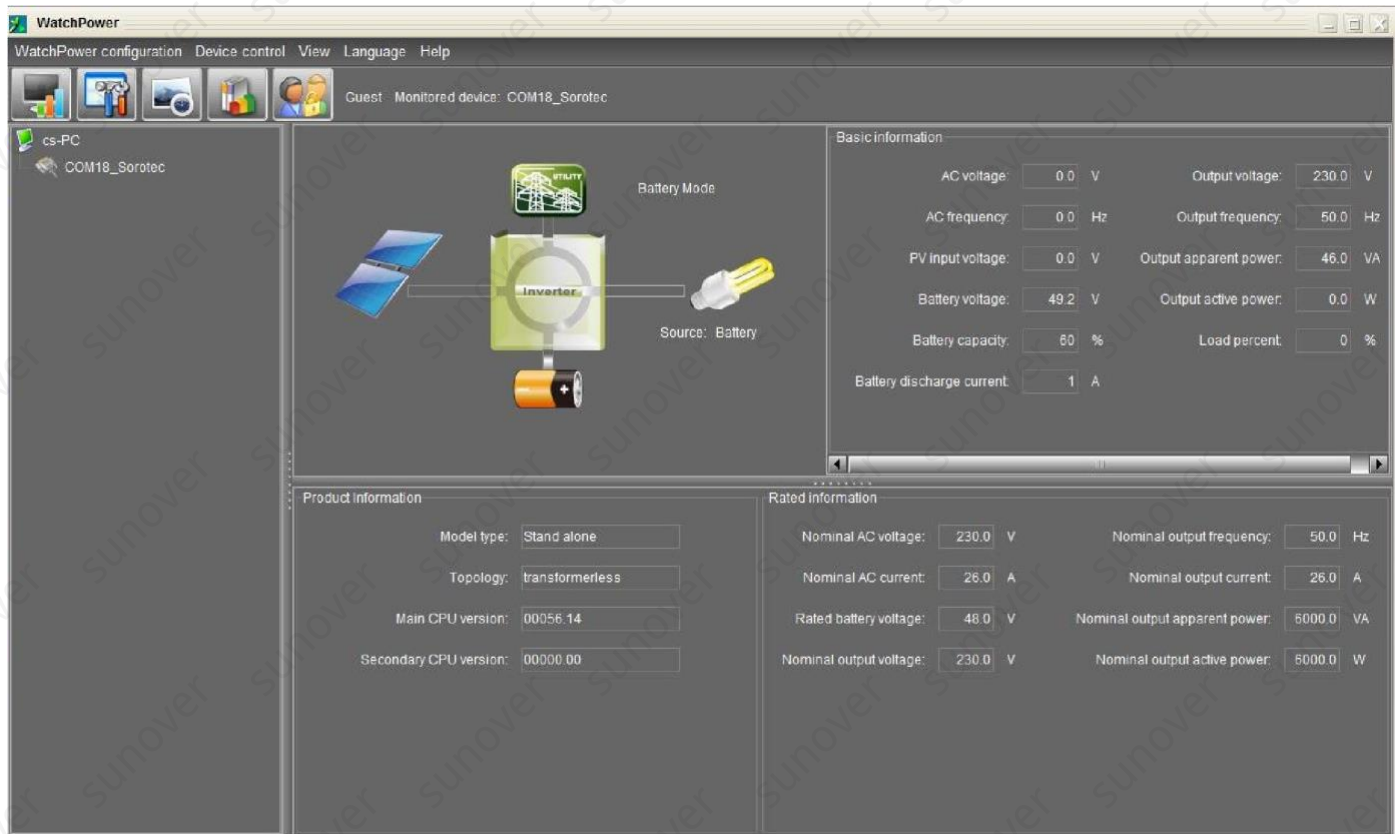

4.9 Wi-Fi Connection(Optional)

- 1.The device has its own standard WIFI port, if users need to monitor the status and information of the device through WIFI, they must connect to the WIFI collector.
- 2.Users can download "SOLAR OF THINGS" WIFI monitoring software from the app store on their phone.
- 3.Inverters come equipped with factory-integrated Wi-Fi capability which makes it very easy to integrate into a home network (Wi-Fi Dongle is Optional)This makes it ideal for local monitoring via the inverter's own wireless home network or for online monitoring platforms.

4.10 Dry Contact Signal

There is one dry contact (3A250VAC) available on the rear panel. It could be used to deliver signal to external device when battery reaches warning level

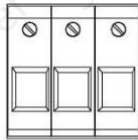
Unit Status	Condition	 NC C NO	
		NC & C	C & NO
Power Off	Unit is off and no output is powered	Open	Close
Power On	Battery voltage <Setting the voltage in program 12	Close	Open
	Battery voltage >Setting the voltage in program 13	Open	Close

5. Operation

5.1 Power ON/OFF



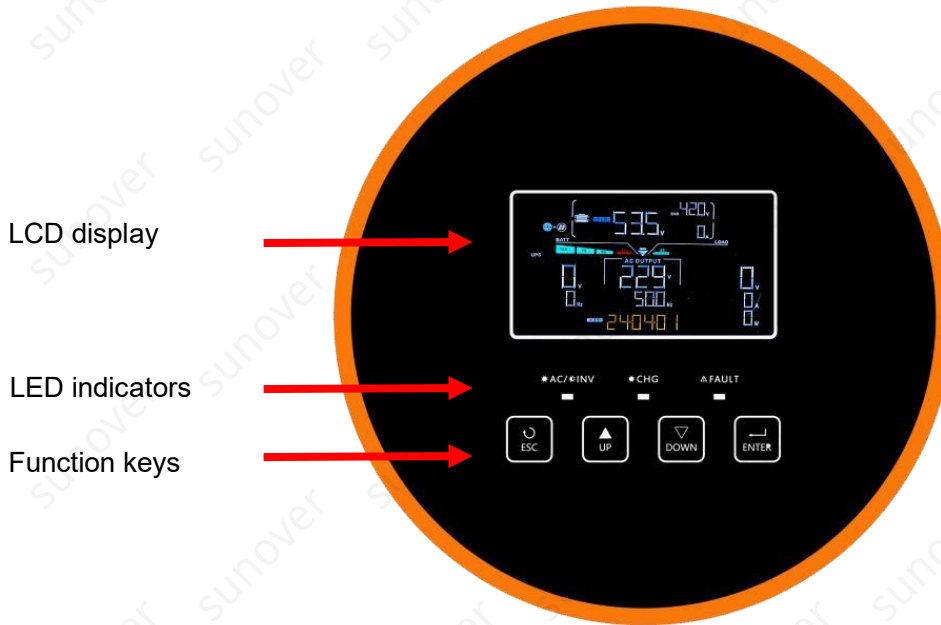

Once the unit has been properly installed and the batteries are connected well, simply press On/Off switch(located on the button of the case) to turn on the unit.

5.2 Operation And Display Panel

The operation LCD panel, shown in the chart below, includes one RGB LED ring, four touchable function keys and a LCD display to indicate the operating status and input/output power information.





Touchable Function Keys

Function Key		Description
	ESC	To exit the setting
	Up	To last selection
	Down	To next selection
	Enter	To confirm/enter the selection in setting mode

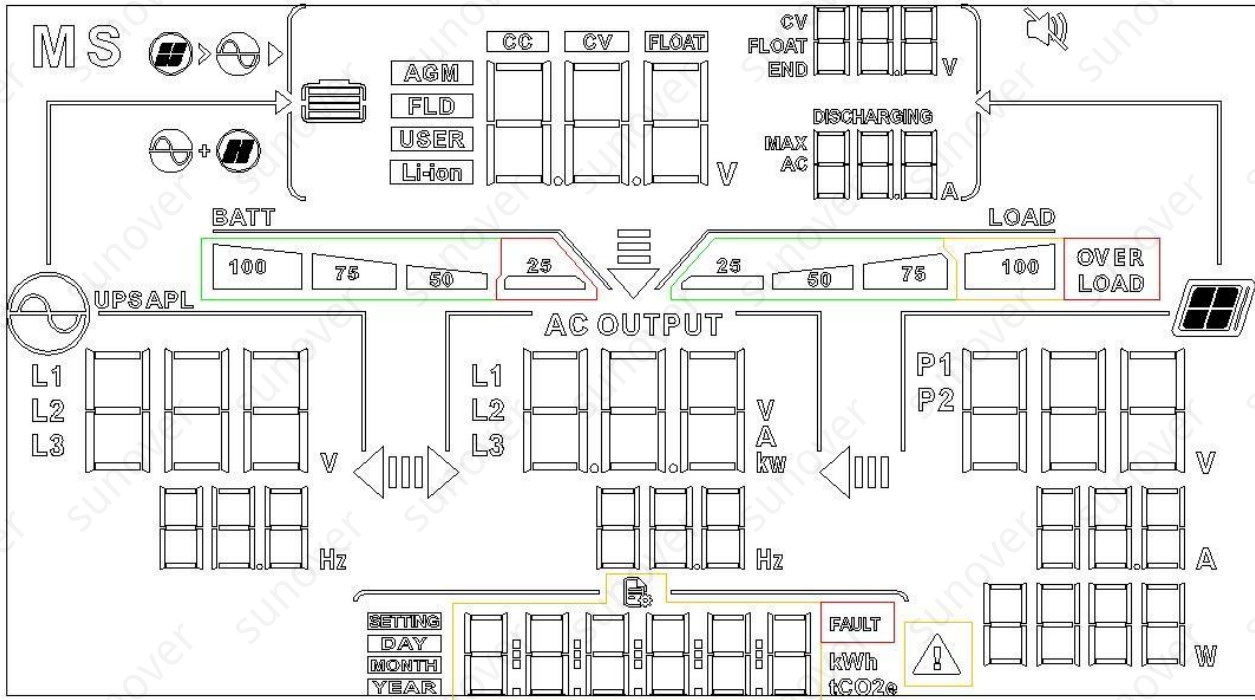

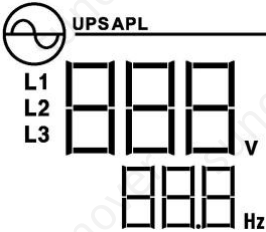
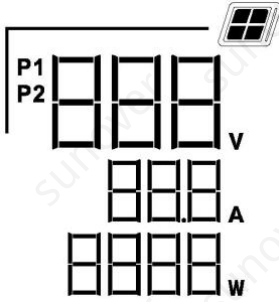
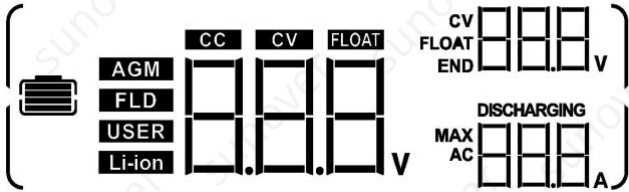

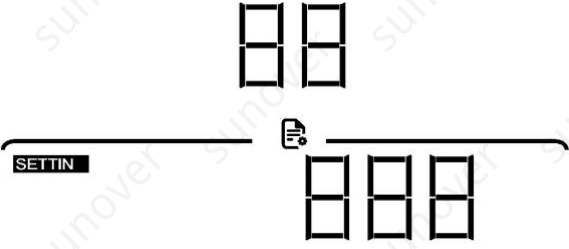
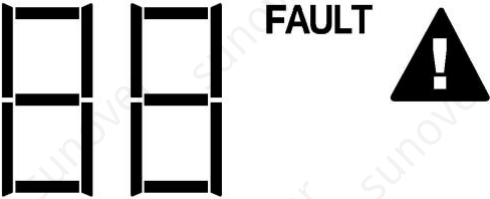
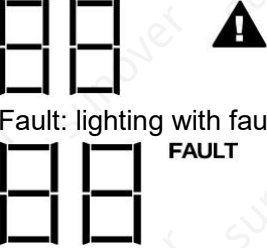
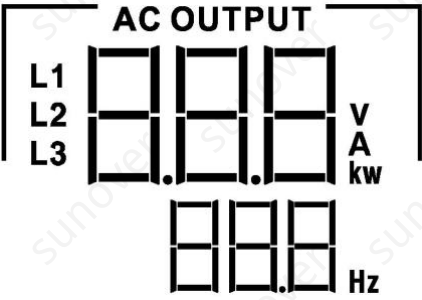
5.3 LCD Display Icons



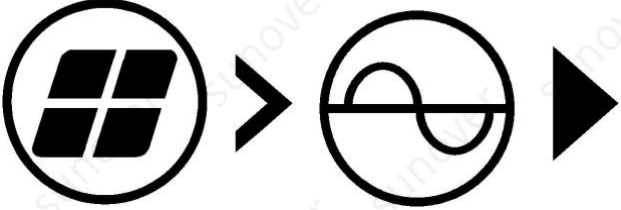
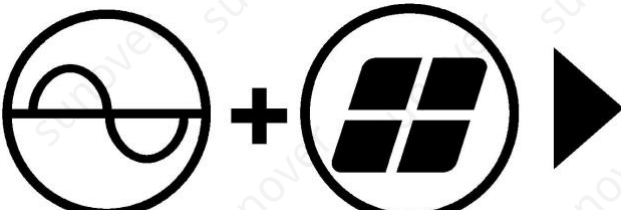
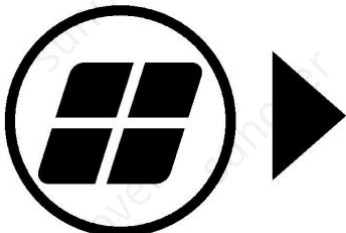

Icon	Function description
<p>Input Source Information</p> 	<p>Indicates the AC input voltage and frequency.</p>
	<p>Indicates the PV voltage, current and power.</p>
	<p>Indicates the battery voltage, charging stage, configured battery parameters, charging or discharging current.</p>



Configuration Program and Fault Information	
	<p>Indicates the setting programs.</p>
	<p>Indicates the warning and fault codes. Warning: flashing with warning code</p>  <p>Fault: lighting with fault code.</p>
Output Information	
	<p>Indicate the output voltage, load in VA, and load in Watt and output frequency.</p>
Battery Information	
<p>BATT</p> 	<ol style="list-style-type: none"> 1.Indicates battery level by 1-25%, 26-49%, 51-75% and 76-100% in battery mode and charging status in line mode. 2.When battery is charging, it will present battery charging status. 3.Floating mode. Batteries are fully charged.4 bars will be on.
Load Information	
<p>OVER LOAD</p>	<p>Indicates overload.</p>



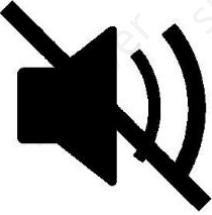

 <p style="text-align: right;">LOAD</p>	<p>Indicates the load level by 0-25%, 26-50%, 51-75% and 76-100%.</p>
---	---

<p>Charger Source Priority Setting Display</p>	
	<p>Indicates setting program 16 "Charger source priority" is selected as "Solar first".</p>
	<p>Indicates setting program 16 "Charger source priority" is selected as "Solar and Utility".</p>
	<p>Indicates setting program 16 "Charger source priority" is selected as "Solar only".</p>
	<p>Indicates setting program 01 "Output source priority" is selected as "Utility first".</p>
	<p>Indicates setting program 01 "Output source priority" is selected as "Solar first".</p>
	<p>Indicates setting program 01 "Output source priority" is selected as "SBU".</p>
<p>AC Input Voltage Range Setting Display</p>	

<h1>APL</h1>	<p>The acceptable AC input voltage range will be within 90-280VAC.</p>
<h1>UPS</h1>	<p>The acceptable AC input voltage range will be within 170-280VAC.</p>

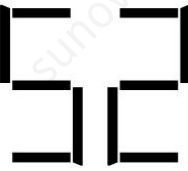
Operation Status Information	
	<p>Indicates unit connects to the mains.</p>
	<p>Indicates unit connects to the PV panel.</p>
<p>AGM</p> <p>FLD</p> <p>USER</p> <p>Li-ion</p>	<p>Indicates battery type.</p>
<p>DAY </p>	<p>Date:Year,Month ,Day</p>

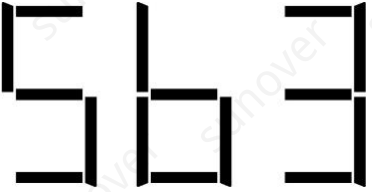

	<p>Power generation</p>
	<p>Indicates unit alarm is disabled.</p>
	<p>“H”: Master unit . “2”: there are two parallel machines in single phase</p>

	<p>“S”: Slave unit. “2”:there are two parallel machines in single phase</p>
	<p>“H”: Master unit “A”: A-phase “3”:there are three parallel machines in three phase</p>
	<p>“S”: Slave unit “B”: B-phase “3”:there are three parallel machines in three phase</p>
	<p>“S”: Slave unit “C”: C-phase “3”:there are three parallel machines in three phase</p>
	<p>Feed back into the grid</p>



5.4 LCD Setting

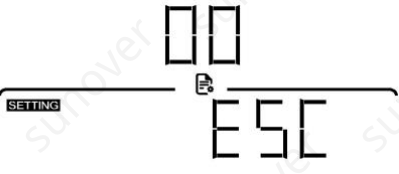
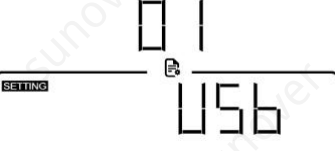

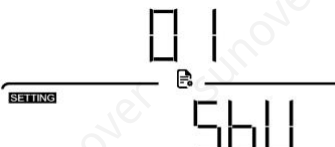
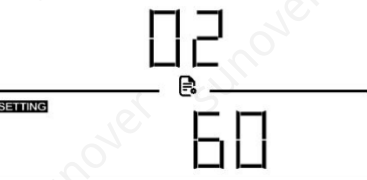

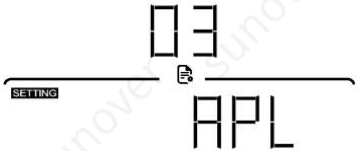
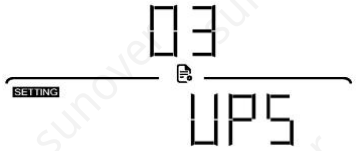
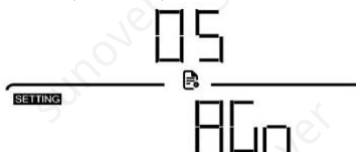
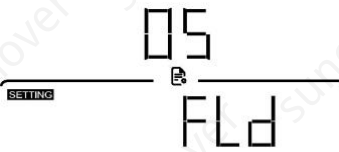
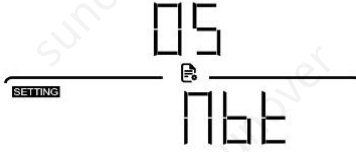
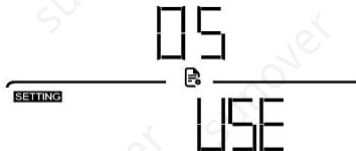
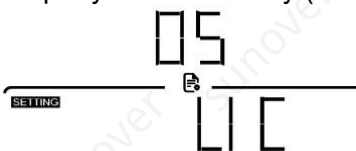
After pressing and holding ENTER button for 3 seconds, the unit will enter setting mode. Press “UP” or “DOWN” button to select setting programs. And then, press “ENTER” button to confirm the selection or ESC button to exit.

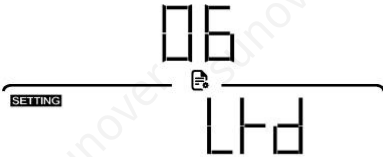
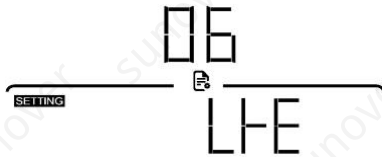
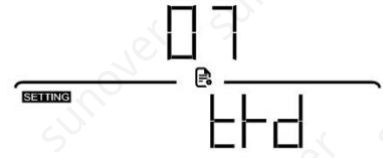
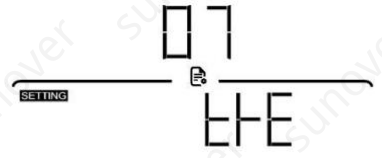
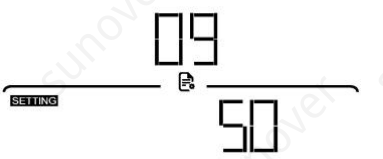
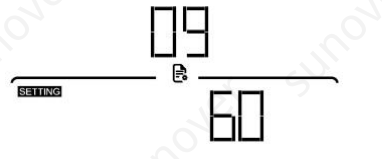
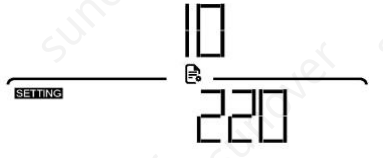
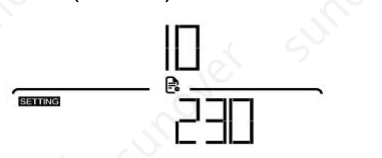

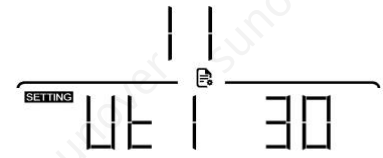
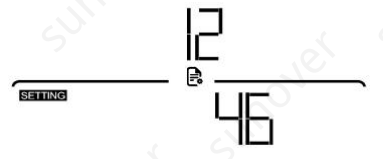
Note: All settings must be modified in battery mode and must be rebooted to be valid. Setting Programs:

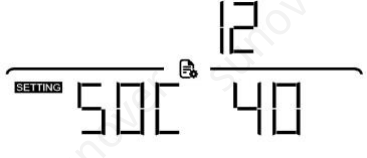

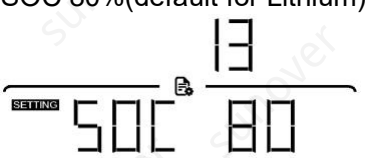

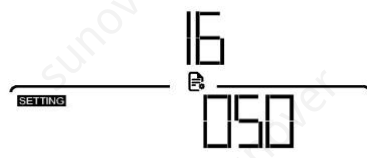
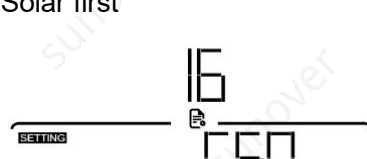

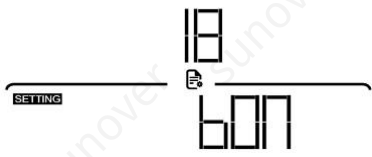
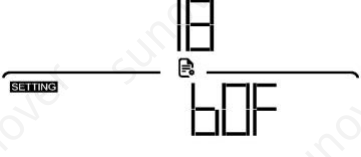
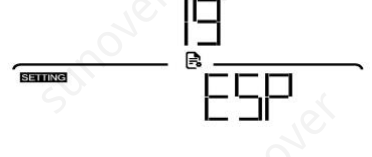
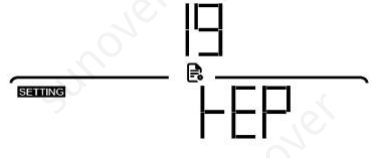
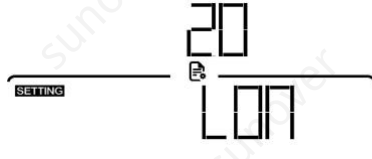
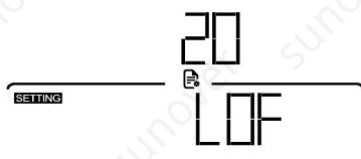
Program	Description	Select able option	
00	Exit setting mode	Escape 	
01	Output source priority: To configure load power source priority	Utility first (default) 	Utility will provide power to the loads as first priority. solar and battery energy will provide power to the loads only when utility power is not available
		Solar first 	Solar energy provides power to the loads as first priority. if solar energy is not sufficient to power all connected loads, Utility energy will supply power to the loads at the same time.
		SBU priority 	Solar energy provides power to the loads as first priority. if solar energy is not sufficient to power all connected loads, battery energy will supply power to the loads at the same time. utility provides power to the loads only when battery voltage drops to either low- level warning voltage or the setting point in program 12.
02	Maximum charging current: (Max. charging current = utility charging current + solar charging current)	60A(default) 	Setting range is 2A, then from 10A to 120A Increment of each click is 10A.

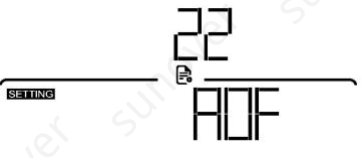
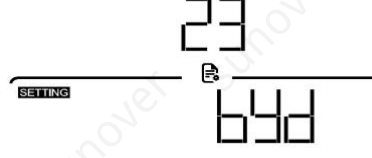
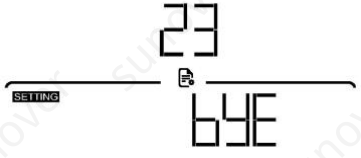
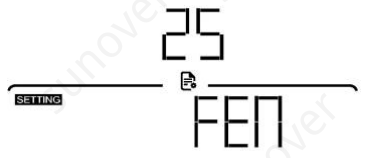
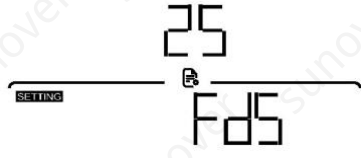
03	AC input voltage range	Appliances (default) 	If selected, acceptable AC input voltage range will be within 90280VAC.
		UPS 	If selected, acceptable AC input voltage range will be within 170280VAC.
05	Battery type	AGM (default) 	Flooded 
		No battery 	
		User-Defined 	If "User-Defined" is selected, battery charge voltage and low DC cut-off voltage can be set up in program 26, 27 and 29.
		3rd party Lithium battery (CAN) 	If selected, programs of 02, 26, 27 and 29 will be automatically set up. No need for further setting. Please contact the battery supplier for installation procedure.
		3rd party Lithium battery (RS485) LI1; LI2; LI3; LI4; LI5	Note: if you have a lithium battery, you can choose this option. When you plug in BMS communications, screen will show "LIC".

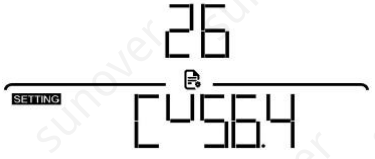

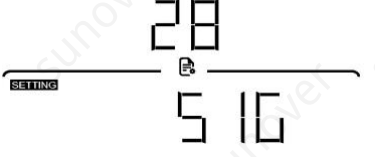
06	Auto restart when overload occurs	Restart disable (default) 	Restart enable 
07	Auto restart when over temperature occurs	Restart disable (default) 	Restart enable 
09	Output frequency	50Hz (default) 	60Hz 
10	Output voltage	220V 	230V (default) 
		240V 	
11	Maximum utility charging current Note: If setting value in program 02 is smaller than that in program in 11, the inverter will apply charging current from program 02 for utility charger.	30A (default) 	Setting range is 2A, then from 10A to 120A Increment of each click is 10A.
12	Setting voltage point back to utility source when selecting "SBU" (SBU priority) in program 01. program 01	46V (default) 	Setting range is from 44V to 51V. Increment of each click is 1V.

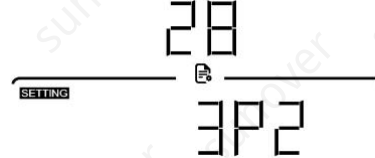
		<p>SOC 40%(default for Lithium)</p> 	<p>If any types of lithium battery is selected in program 05, setting value will change to SOC automatically. Adjustable range is 10% to 80%.</p>
	second output	<p>When the battery voltage is lower second output will be turned off immediately after 5 seconds. If the main is connected, the second output will be turned on immediately</p>	<p>than the 12 setting points, the immediately after 5 seconds. If the</p>
13	Setting voltage point back to battery mode when selecting "SBU" (SBU priority) in program 01.	<p>13</p> 	<p>54V (default) Setting range is from 48V to 58V. Increment of each click is 1V.</p>
		<p>SOC 80%(default for Lithium)</p> 	<p>If any types of lithium battery is selected in program 05, setting value will change to SOC automatically. Adjustable range is 50% to 100%. Increment of each click is 5%</p>
16	Charger source priority: To configure charger source priority	<p>If this inverter/charger is working in Line, Standby or Fault mode, charger source can be programmed as below:</p>	
		<p>Solar and Utility (default)</p> 	<p>Solar energy and utility will charge battery at the same time.</p>
		<p>Only Solar</p> 	<p>Solar energy will be the only charger source no matter utility is available or not.</p>
		<p>Solar first</p> 	<p>Solar energy will charge battery as first priority. Utility will charge battery only when solar energy is not available.</p>

18	Alarm control	Alarm on (default) 	Alarm off 
19	Auto return to default display screen	Return to default display screen (default) 	If selected, no matter how users switch display screen, it will automatically return to default display screen after no button is pressed for 1 minute.
		Stay at latest screen 	If selected, the display screen will stay at latest screen user finally switches.
20	Backlight control	Backlight on 	Backlight off 
22	Beeps while primary source is interrupted	Alarm on (default) 	Alarm off 
23	Overload bypass: When enabled, the unit will transfer to line mode if overload occurs in battery mode.	Bypass disable (default) 	Bypass enable 
25	Record Fault code	Record enable (default) 	Record disable 

26	Bulk charging voltage (C.V voltage)	Available options for 48V model: 56.4V (default) 	If user-defined is selected in program 5, this program can be set up. Setting range is from 48.0V to 61.0V. Increment of each click is 0.1V.
27	Floating charging voltage	Available options for 48V model: 54.0V (default) 	If user-defined is selected in program 5, this program can be set up. Setting range is from 48.0V to 61.0V. Increment of each click is 0.1V.
28	Single and Parallel setting	default 	Single enable
		single-phase parallel 	single-phase parallel enable
		A phase 	A-phase parallel enable
		B phase 	B-phase parallel enable
		C phase 	C-phase parallel enable

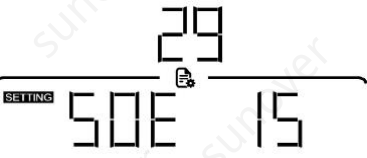
		<p>Please note:</p> <ol style="list-style-type: none"> 1. when three-phase parallel,make sure that A-phase is the host; 2. after the parallel parameters are modified,the device must be restarted to be effective. 3. All inverters must share the same battery pack when paralleling 4. This setting is only available when the inverter is in standby mode (Switch off).
--	--	---

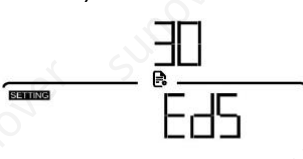
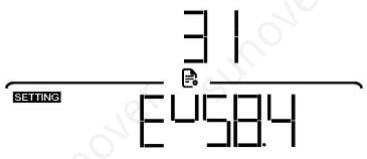
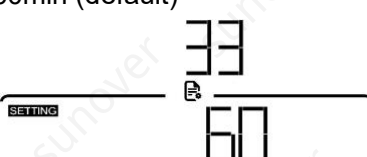

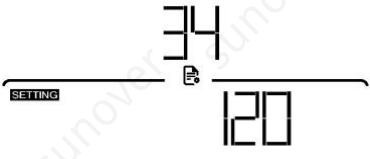
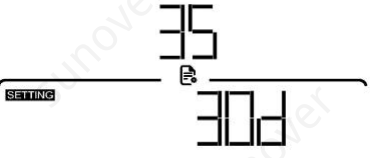
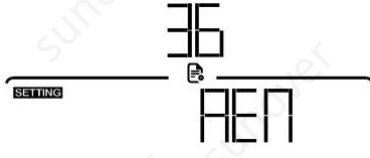
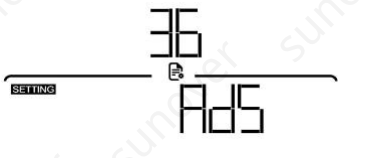
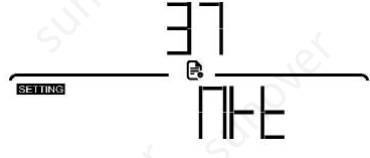
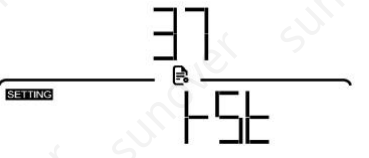
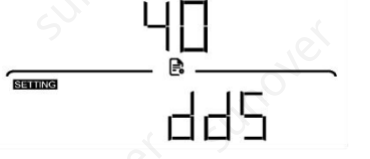

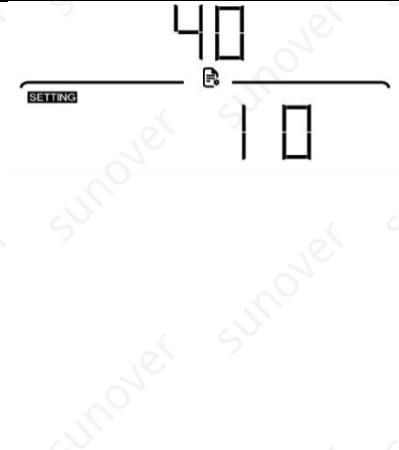

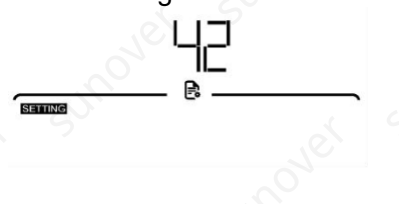
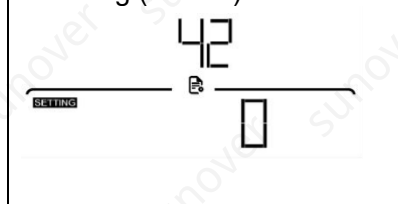
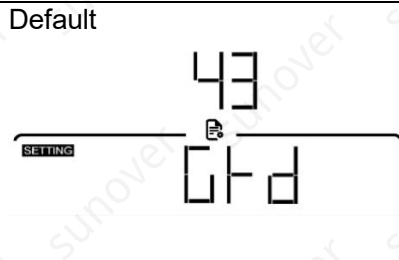
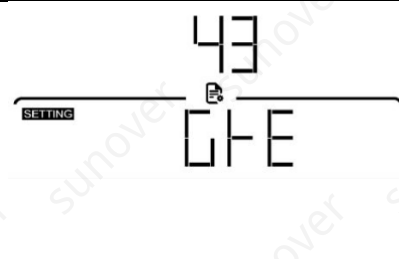
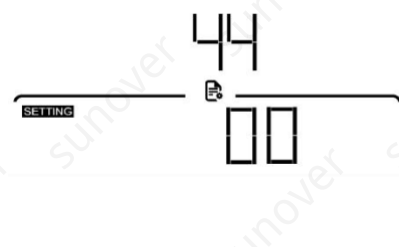
29	Low DC cut-off voltage	<p>Available options for 48V model: 42.0V (default)</p> 	<p>If user-defined is selected in program 5, this program can be set up. Setting range is from 42.0V to 52.0V. Increment of each click is 0.1V. Low DC cutoff voltage will be fixed to setting value no matter what percentage of load is connected.</p>
			<p>If Lithium battery is selected in program 5,setting value will change to SOC automatically.Setting range is From 5% to 50%.</p>
30	Battery equalization	<p>Battery equalization enable</p> 	<p>Battery equalization disable (default)</p> 
		<p>Note: If "Flooded" or "User-Defined" is selected in program 05, this program can be set up.</p>	
31	Battery equalization voltage	<p>58.4V (default)</p> 	<p>Setting range is from 48.0V to 61.0V. Increment of each click is 0.1V.</p>
33	Battery equalized time	<p>60min (default)</p> 	<p>Setting range is from 5min to 900min. Increment of each click is 5min.</p>

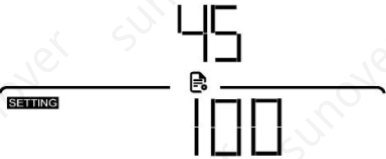

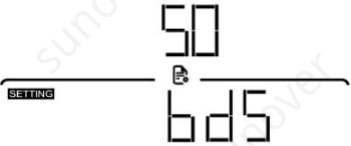
34	Battery equalized timeout	120min (default) 	Setting range is from 5min to 900 min. Increment of each click is 5 min.
35	Equalization interval	30days (default) 	Setting range is from 0 to 90 days. Increment of each click is 1 day.
36	Equalization activated immediately	Enable 	Disable (default) 
		If equalization function is enabled in program 30, this program can be set up. If “Enable” is selected in this program, it’s to activate battery equalization immediately and LCD main page will show “E9”. If “Disable” is selected, it will cancel equalization function until next activated equalization time arrives based on program 35 setting. At this time, “E9” will not be shown in LCD main page.	
37	Reset all stored data for PV generated power and output load energy	Not reset(Default) 	Reset 
40	Discharge limited current		discharge current limited disable

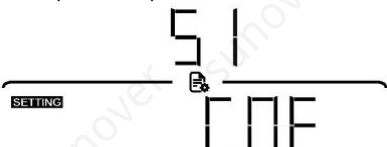
			<p>setting range :10A to 300A setting increase or decrease of 10A .</p> <p>NOTE:1. if you work in “SUB mode” or “SBU mode”, when the loads is greater than the current limiting point, it will automatically switch to utility mode. 2.if it only works in battery mode, when the load is greater than the current limiting point ,the inverter will shut down immediately.</p>
--	--	--	--

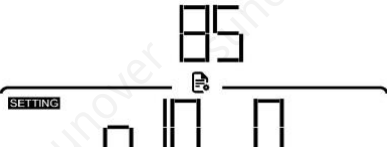
42	Adjustment parameter for EARTH LED	<p>If unit is not in Line mode,it will show nothing.</p> 	<p>If unit is in Line mode,it will show following.(default)</p> 
		<p>If EARTH LED of meter is on,it can be off by adjusting the parameter.If the unit is in Line mode, this program can be set up.Setting range is form -30 to 30 .Increment of each click is 1.The condition of program changed automatically.</p>	
43	Solar energy feed to grid	<p>Default</p> 	Solar energy feed to grid disable
			Solar energy feed to grid enable
44	Re connection delay time		<p>When the utility is connected, the waiting time can be set. After reaching the waiting time, the utility will start working. Range:0-999S</p>

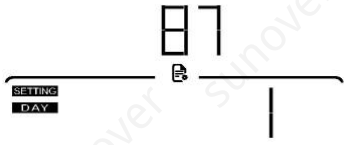

45	Zero-export to Load	<p>If unit is not in Line mode,it will show nothing.</p> 	<p>If unit is in Line mode,it will show following.(Default)</p> 
		<p>If REVERSE LED of meter is on,it can be off by adjusting the parameter.If the unit is in Line mode,this program can be set up.Setting range is from 0 to 500.Increment of each click is 10.</p>	

50	Battery activation	<p>OFF(Default)</p> 	<p>Manual activation : In this mode, select "On", connect the AC or PV to the inverter, and turn it on. If the battery is not detected, an activation of the battery is performed. "Off" will be returned if activation is successful or fail</p>
		<p>ON</p> 	
51	CT enable	<p>OFF(Default)</p> 	<p>ON</p> 
85	Time setting – Minute		<p>For minute setting, the range is from 0 to 59.</p>
86	Time setting – Hour		<p>For hour setting, the range is from 0 to 23.</p>

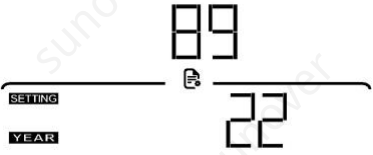
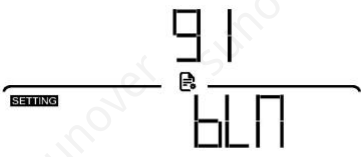
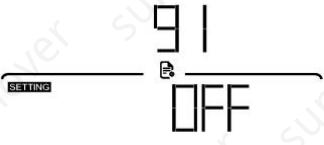
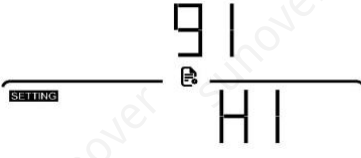
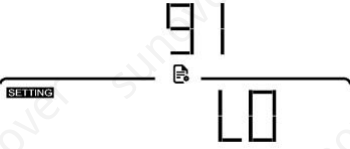
87	Time setting– Day		For day setting, the range is from 1 to 31.
88	Time setting– Month		For month setting, the range is from 1 to 12.

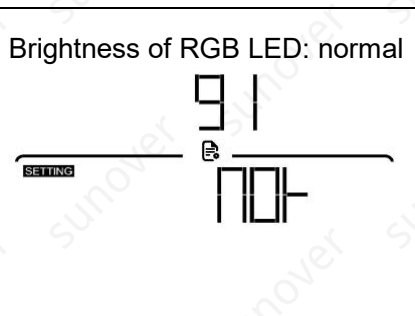
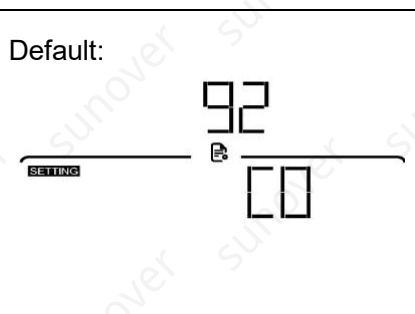
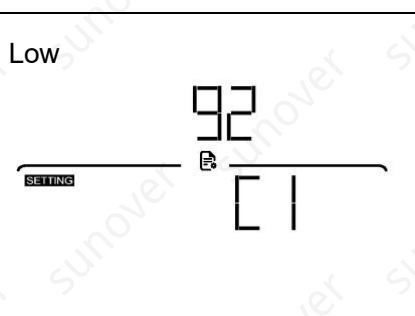
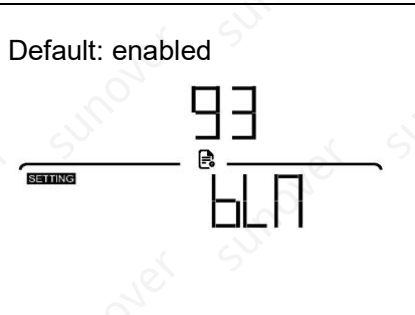
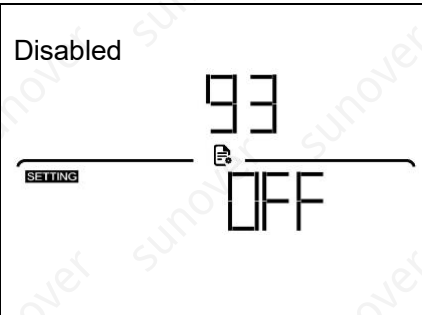
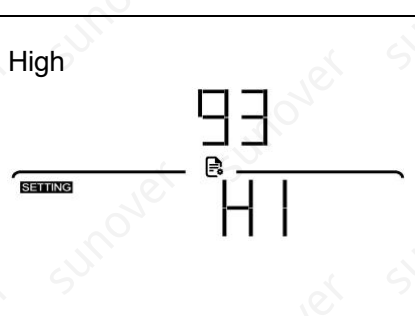
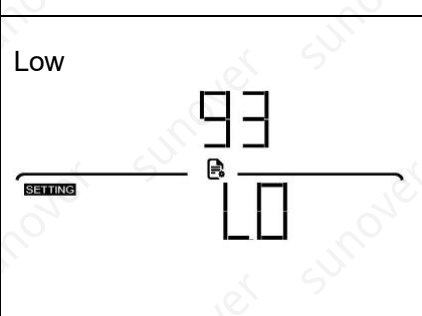
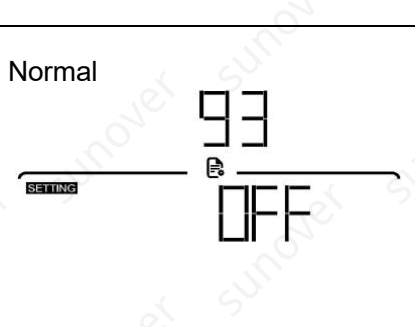
89	Time setting – Year		For year setting, the range is from 17 to 99.
91	Surround RGB brightness	<p>Default:</p> 	<p>Default: Breathing light effect disabled</p> 
		<p>On/Off control for RGB LED,It's necessary to enable this setting to activate RGB LED lighting functi n.</p>	
		<p>Brightness of RGB LED: high</p> 	<p>Brightness of RGB LED: low</p> 

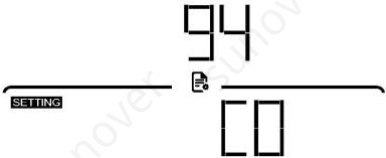
		Brightness of RGB LED: normal 	
92	Surrounding the RGB LED lighting color	Default: 	The cycle of seven kinds of color.
		Low 	“01” to “07” can be used in one of the colors
93	The Logo of brightness of RGB LED	Default: enabled 	Disabled 
		High 	Low 
		Normal 	

94	The Logo color of RGB LED		The cycle of seven kinds of color.
			“01” to “07” can be used in one of the colors

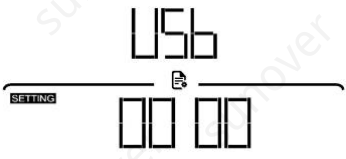
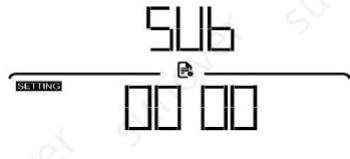
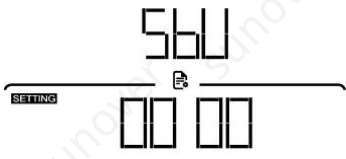
99	Timer Setting for Output source Priority 	Once access this program, it will show “OPP” in LCD. Press “←” button to select timer setting for output source priority. There are three timers to set up. Press “▲” or “▼” button to select specific timer option. Then, press “←” to confirm timer option. Press “▲” or “▼” button to adjust starting time first and the setting range is from 00 to 23. Increment of each click is one hour. Press “←” to confirm starting time setting. Next, the cursor will jump to right column to set up end time. Once end time is set completely, press“←” to confirm all setting.	
		Utility first timer 	Solar first timer 
		SBU priority timer 	

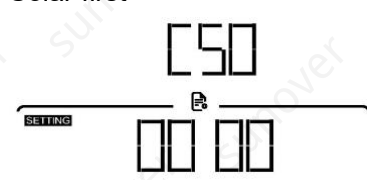
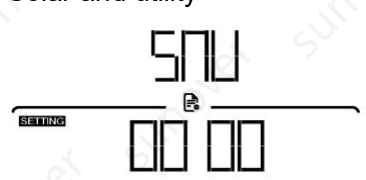
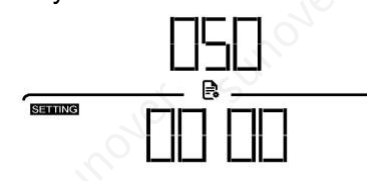
100	<p>Timer Setting for Charger Source Priority</p> 	<p>Once access this program, it will show "CGP" in LCD. Press "←" button to select timer setting for charger source priority. There are three timers to set up. Press "↑" or "↓" button to select specific timer option. Then, press "←" to confirm timer option. Press "↑" or "↓" button to adjust starting time first and the setting range is from 00 to 23. Increment of each click is one hour. Press "←" to confirm starting time setting. Next, the cursor will jump to right column to set up end time. Once end time is set completely, press "←" to confirm all setting.</p>	
	<p>Solar first</p> 	<p>Solar and utility</p> 	
	<p>Only solar</p> 		

5.5 LCD Display

The LCD display information will be switched in turn by pressing the " " or "↑" button. The select able information is switched as the following table in order.

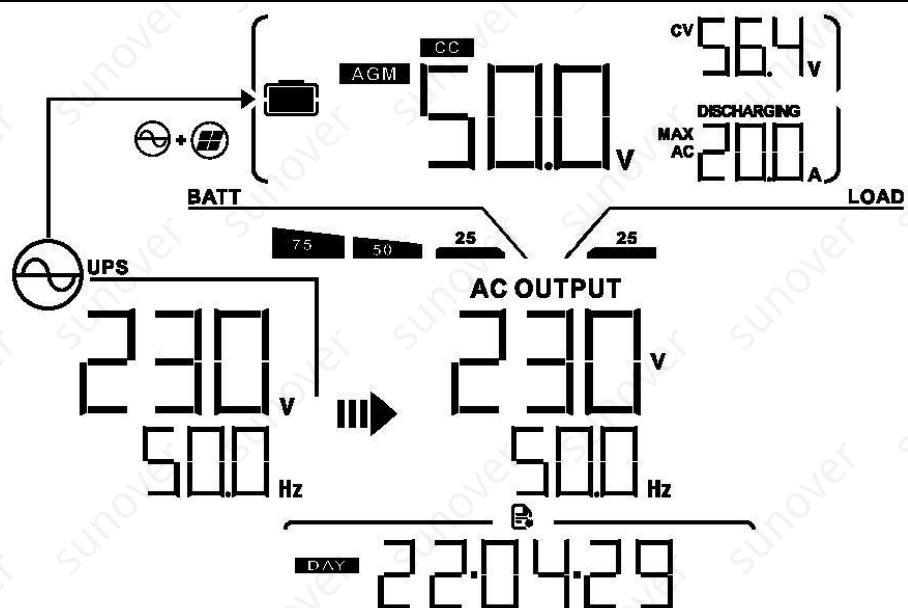
Select able information	Default LCD display
Utility voltage=230Vac Utility frequency=50.0Hz Output voltage=230Vac Frequency=50.0Hz	

PV1 voltage=350V
 PV1 current=2.0A
 PV1 power=700W
 (PV1 and PV2 switch every 5 seconds)

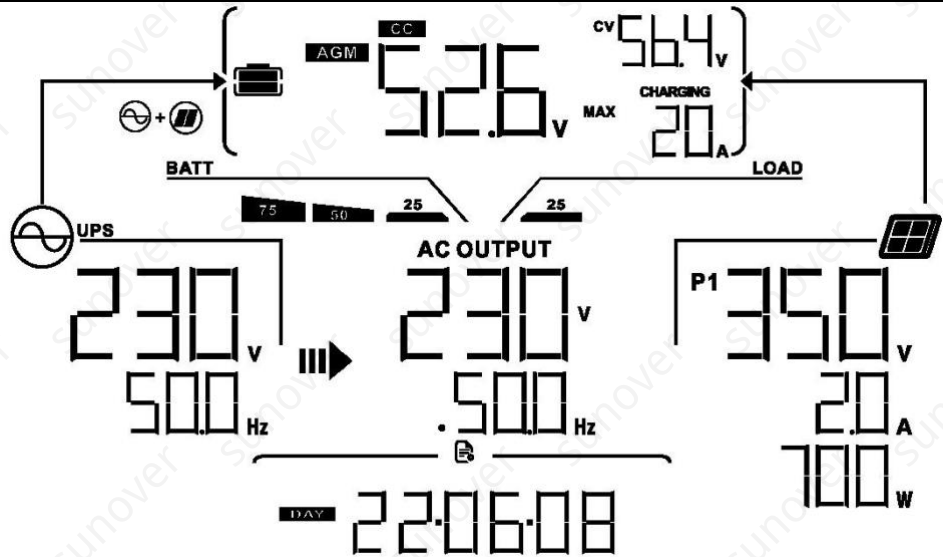

PV2 voltage=350V
 PV2 current=2.0A
 PV2 power=700W
 (PV1 and PV2 switch every 5 seconds)

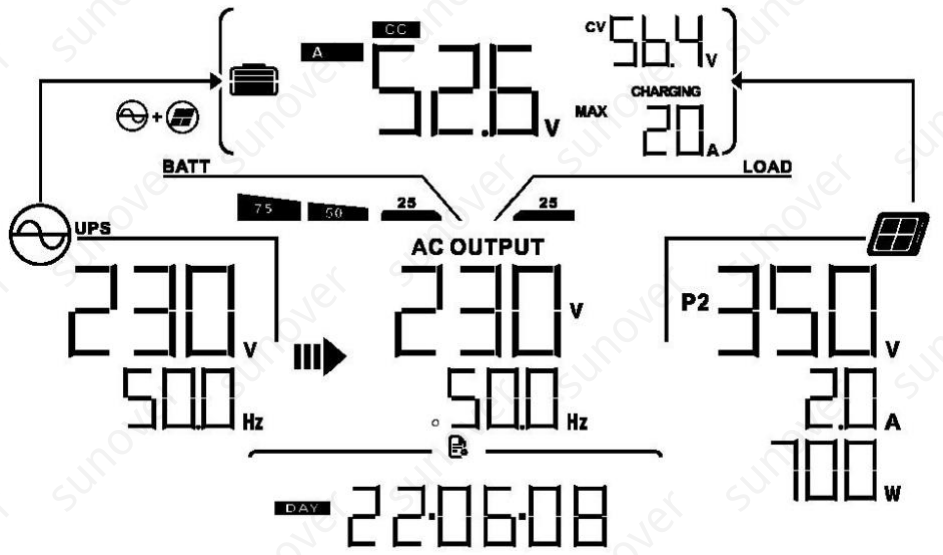

Battery voltage=52.6Vdc
 Bulk charging voltage=56.4Vdc
 Charging current=20A

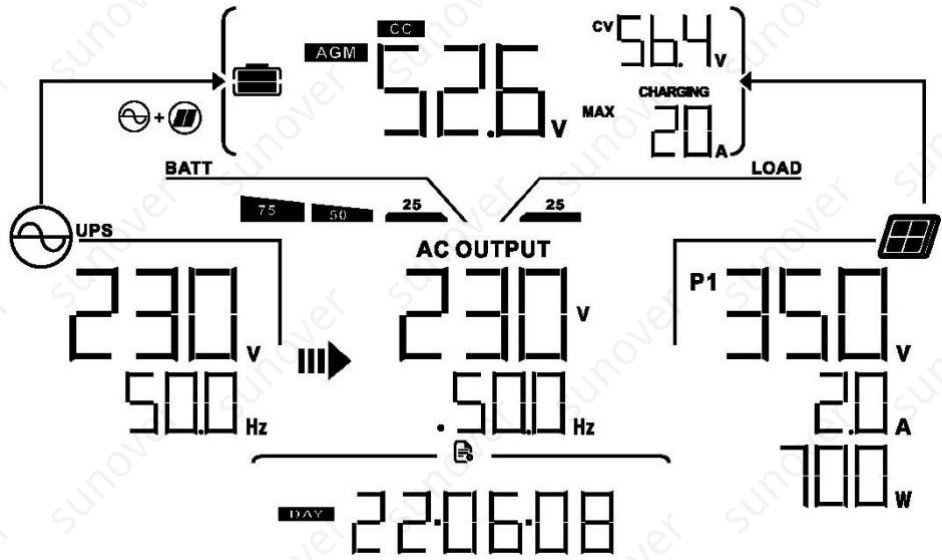

Battery voltage=53.9V
 Floating charging voltage=54.0
 Charging current=0.5A

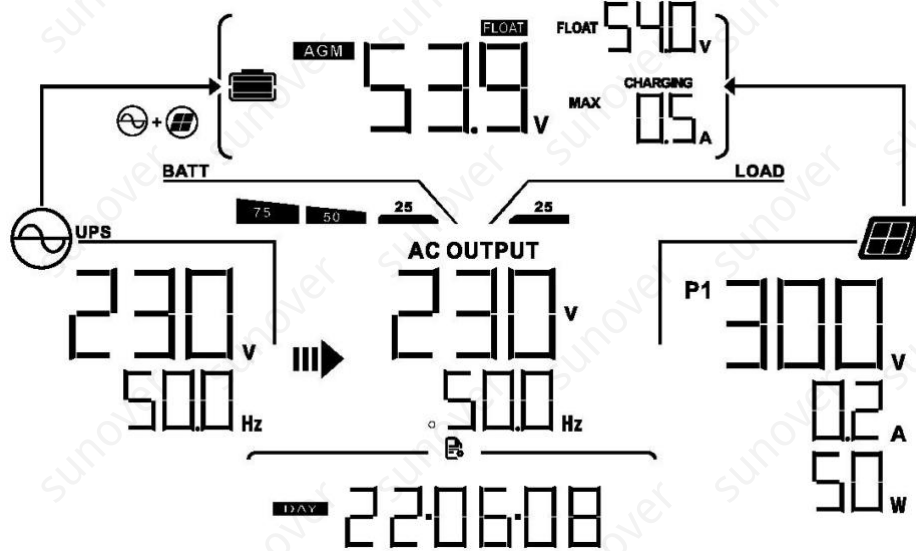

Low DC cut-off voltage=44.0V,
Discharging current=50.0A

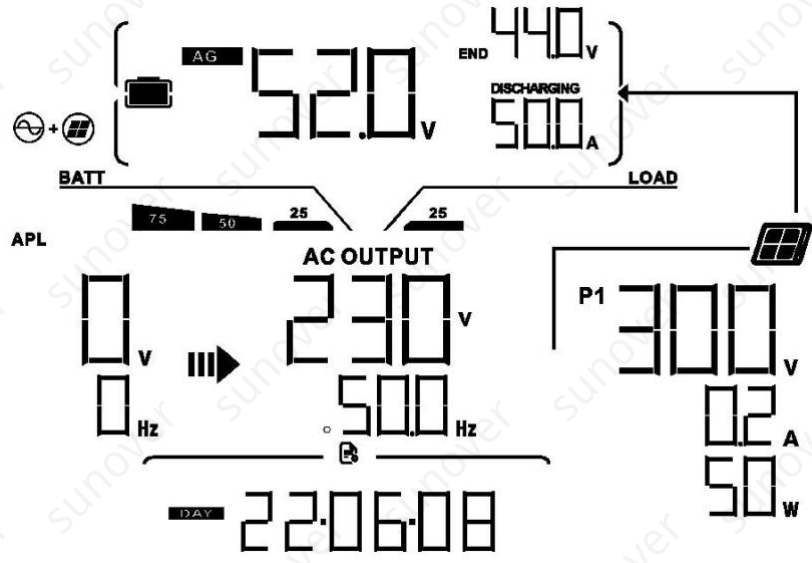

Output power=1.83KVA
Note: Output voltage, load in KVA, load in Watt switch every 5 second

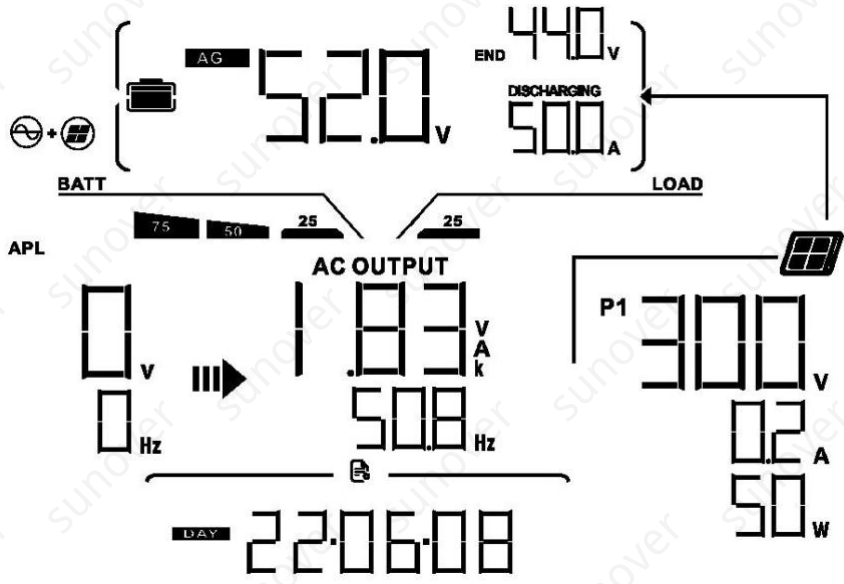

Output power=1.83KW
Note: Output voltage,
 load in KVA, load in
 Watt switch every 5
 second

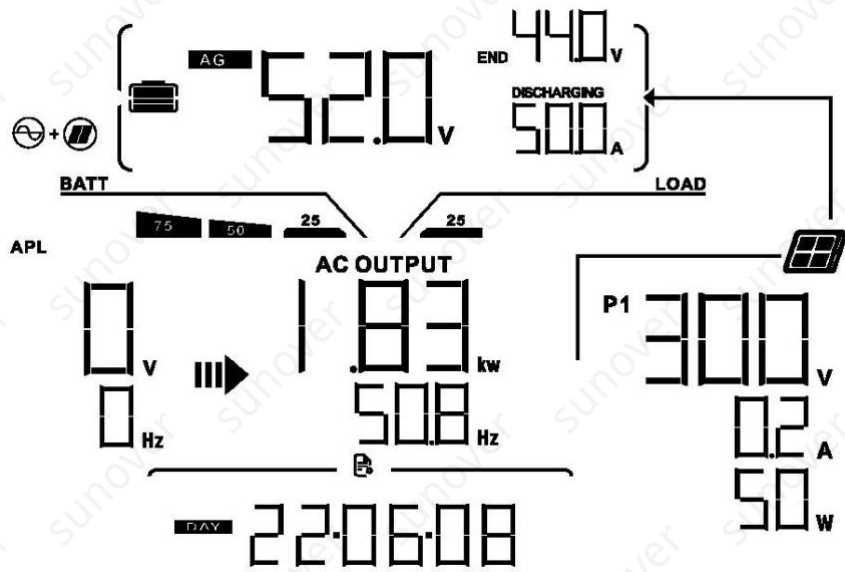

Date: June 8, 2022

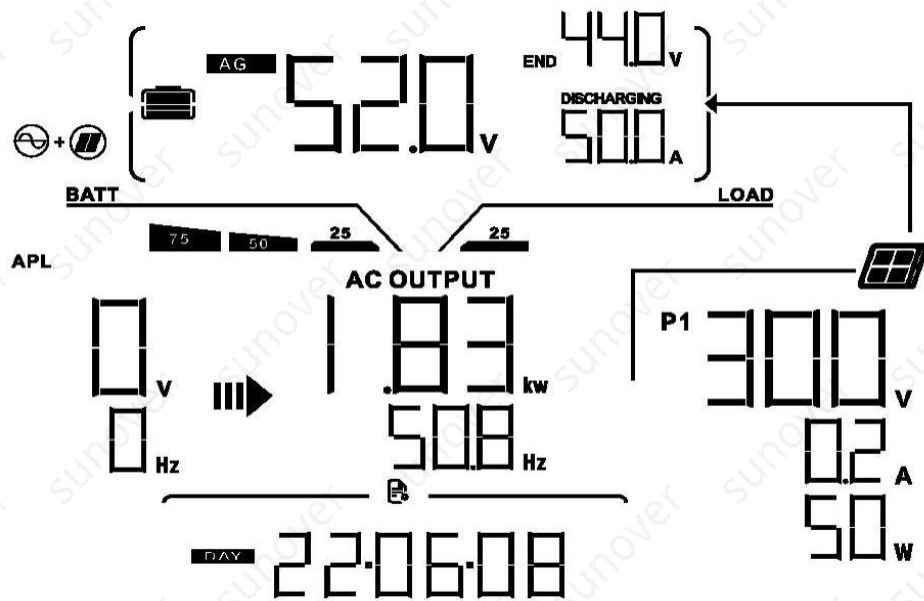

Real time 17:25.

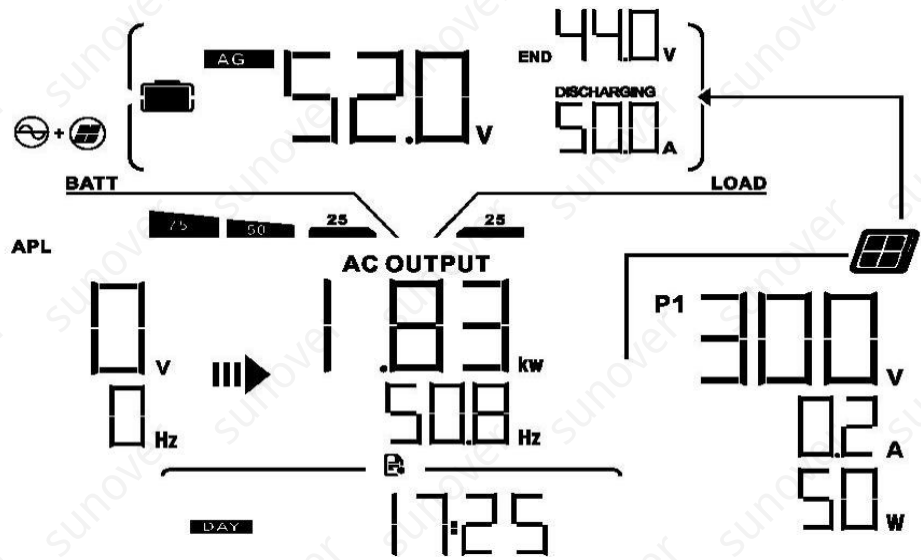

PV energy generation today =528Wh.

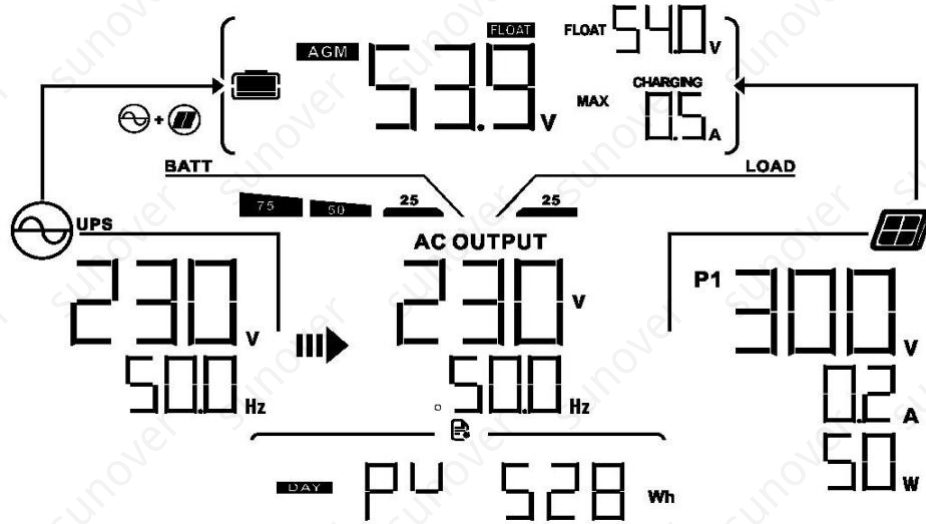

Total PV energy generation

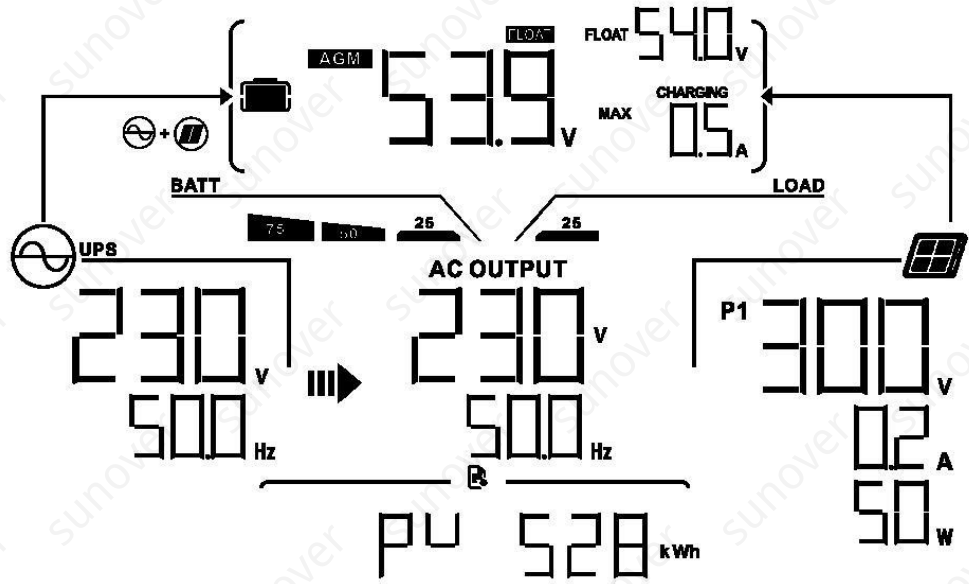

Load output energy today = 528Wh.

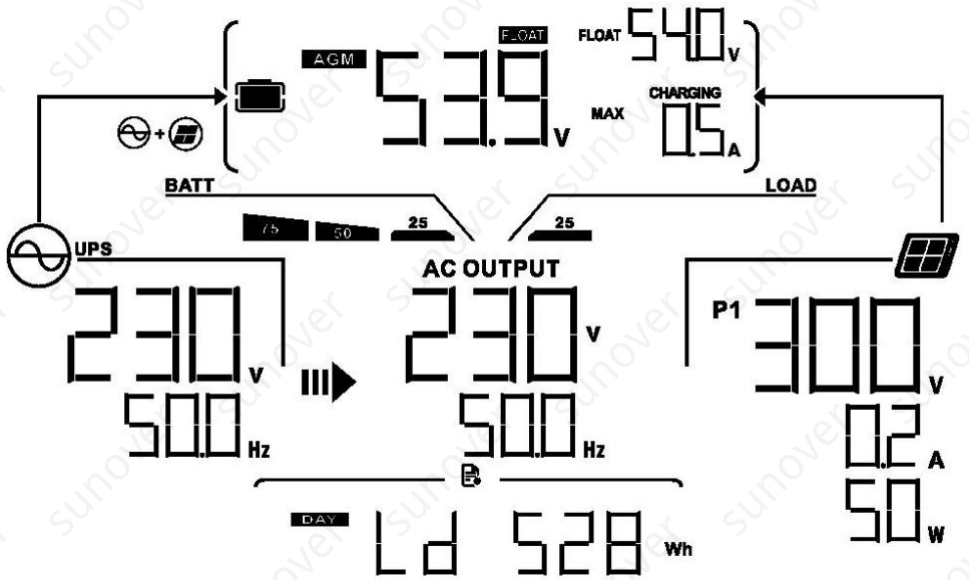

Total load energy
=528KWH

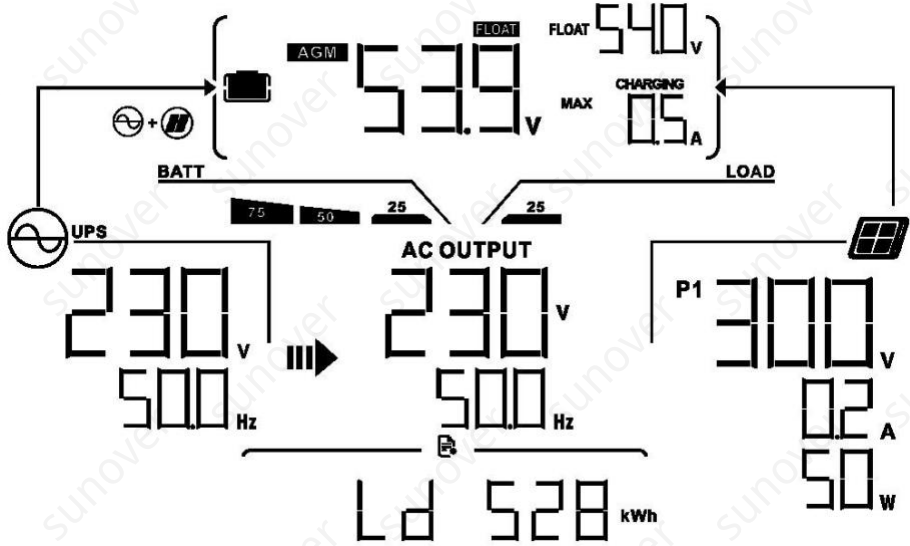

CT:528Wh

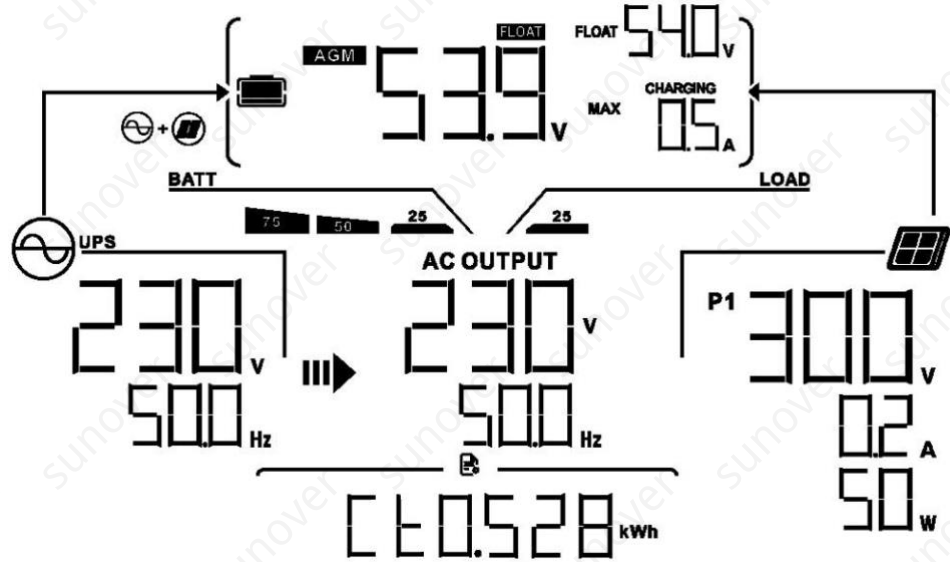

Display control board
software version:0021

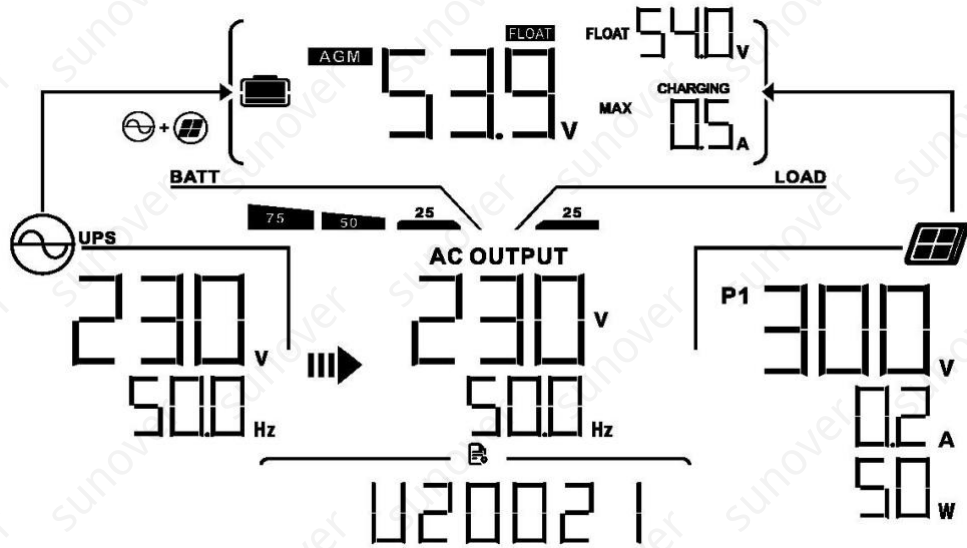

Inverter control board
software version:0031

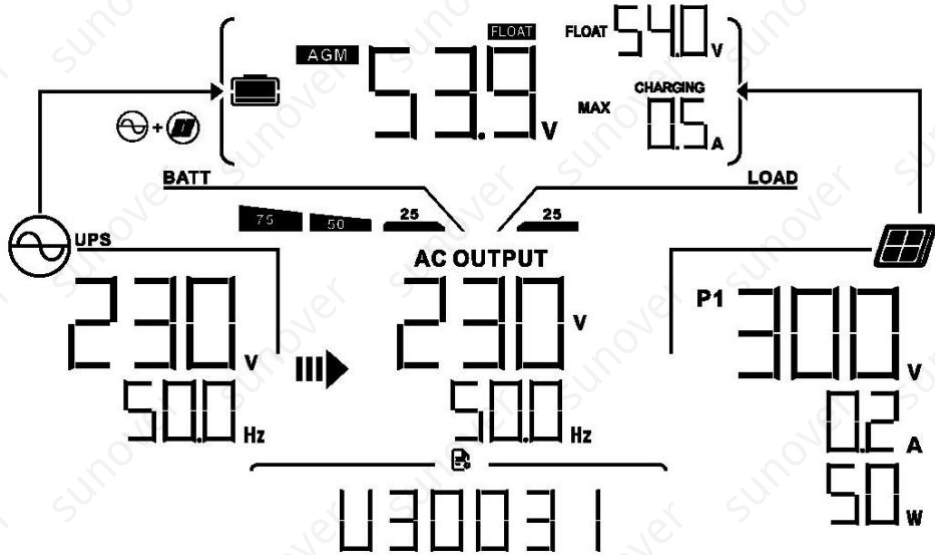

6. Parallel Installation Guide

6.1 Parallel Operation Cable

1. Recommended battery cable and terminal size for each inverter:

Model	Typical Amperage	Battery capacity	Wire Size	Cable mm ²	Ring Terminal		Torque value
					Dimensions		
					D	L	
10KW	208A	250AH	1*3/0AWG	85	8.4	54	5Nm

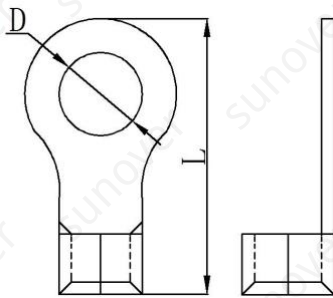

WARNING: Be sure the length of all battery cables is the same. Otherwise, there will be voltage difference between inverter and battery to cause parallel inverters not working.

2. Recommended breaker specification of battery for each inverter:

Model	1 unit*X
10KW	250A70Vdc

If you want to use only one breaker at the battery side for the whole system, the rating of the breaker should be X times current of 1 unit. "X" indicates the number of inverters connected in parallel.

3. Recommended AC input and output cable size for each inverter

Model	Gauge	Torque Value			
10KW	6AWG	1.4~1.6Nm			
Model	2 units	3 units	4 units	5 units	6units
10KW	140A/230VAC	210A/230VAC	280A/230VAC	350A/230VAC	420A/230VAC

Note 1: Also, you can use 70A breaker with only 1 unit and install one breaker at its AC input in each inverter.

Note 2: Regarding three-phase system, you can use 4-pole breaker directly and the rating of the breaker should be compatible with the phase current limitation from the phase with maximum units. **WARNING:** Regarding AC input and output, please also follow the same principle. should be compatible with the phase current limitation from the phase with maximum units.

6.2 Matters Needing Attention In Single-phase Parallel Operation

1. Parallel operation in single phase with up to 6 units.
2. **WARNING:** It's required to connect battery for parallel operation, it is forbidden to use parallel without batteries
3. **WARNING:** It is forbidden for inverter to share the same solar panel group.
4. **WARNING:** Make sure all cables are of the same length, Otherwise, there will be voltage difference between inverter and battery to cause parallel inverters not working.
5. Set the parameters of each inverter separately (working mode, single - phase parallel function).

Warning: When working in parallel, the working mode of each inverter must be the same working mode, output frequency.

6. After setting the parameters, turn on each inverter in turn.

7. **WARNING:** When running in parallel, all inverters must share the battery pack.

6.3 Single-phase Parallel Operation Cable Connection

1.Two inverters in parallel :

Power Connection:

NOTE: The following picture only for your reference. It is subject to actual goods to be received.

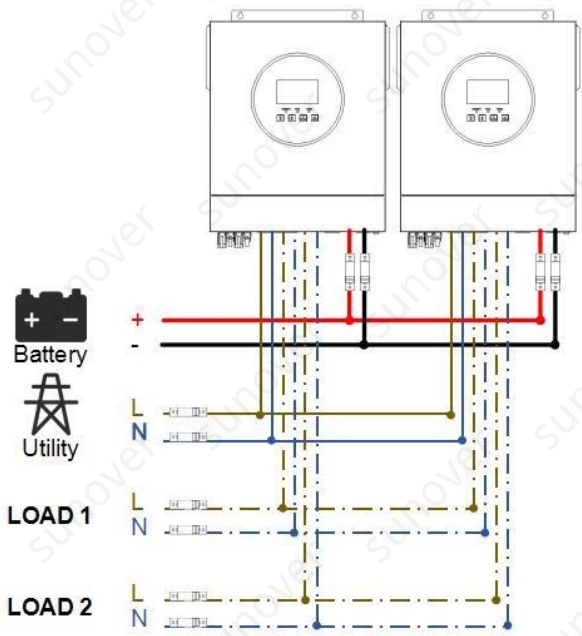

Communication Connection



2.Three inverters in parallel:

Power Connection:

NOTE: The following picture only for your reference. It is subject to actual goods to be received.

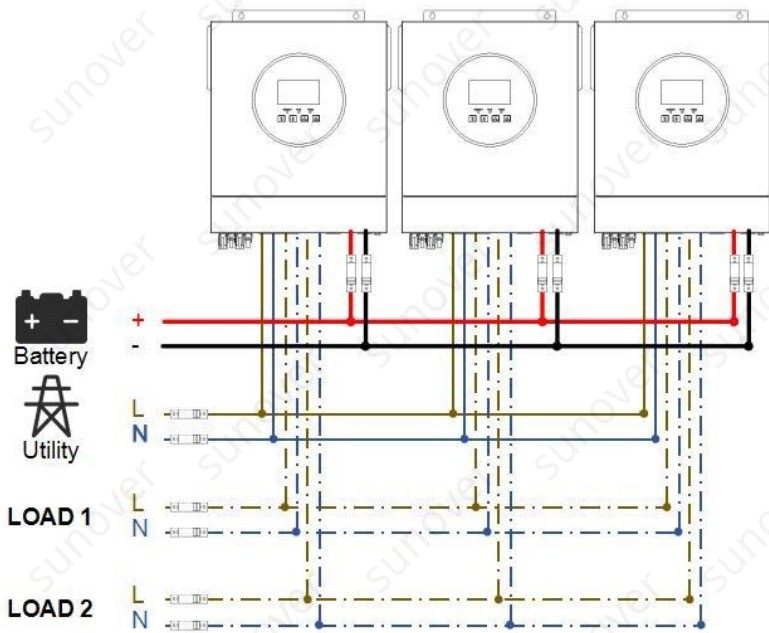

Communication Connection

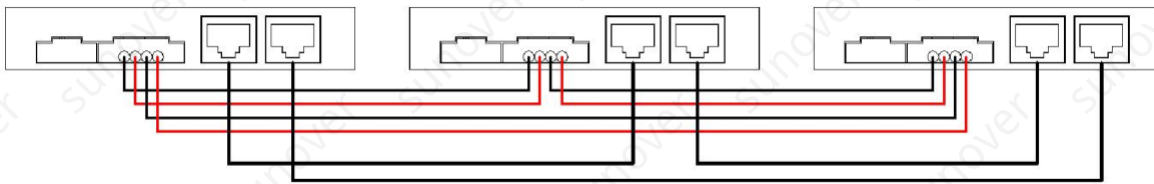

3. Four inverters in parallel :

Power Connection:

NOTE: The following picture only for your reference. It is subject to actual goods to be received.

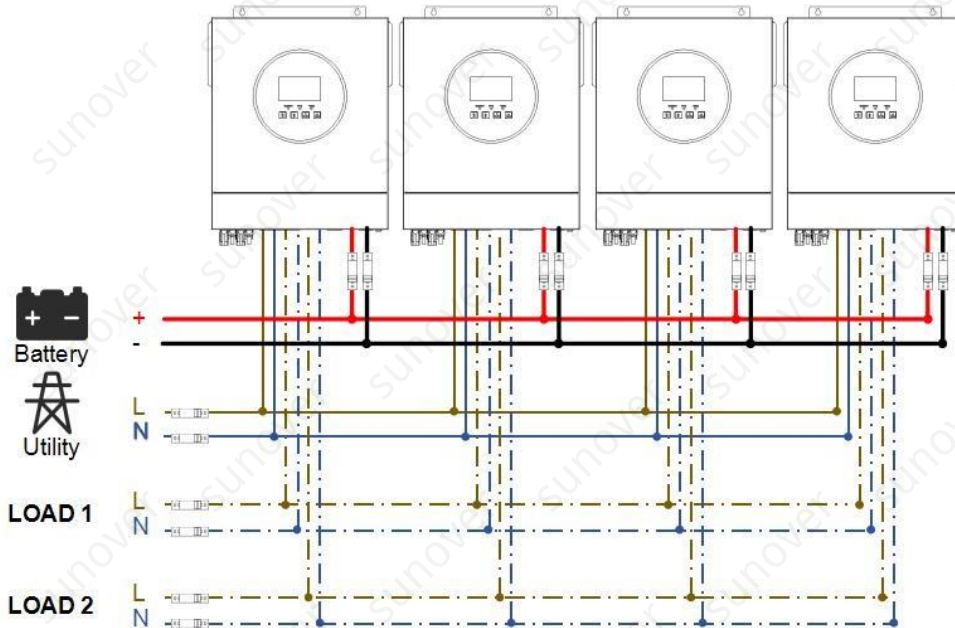

Communication Connection

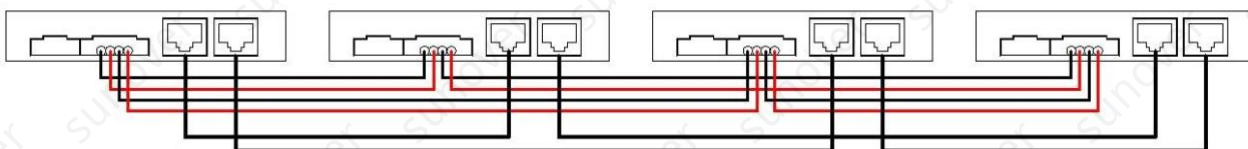

4. Five inverters in parallel :

Power Connection:

NOTE: The following picture only for your reference. It is subject to actual goods to be received.

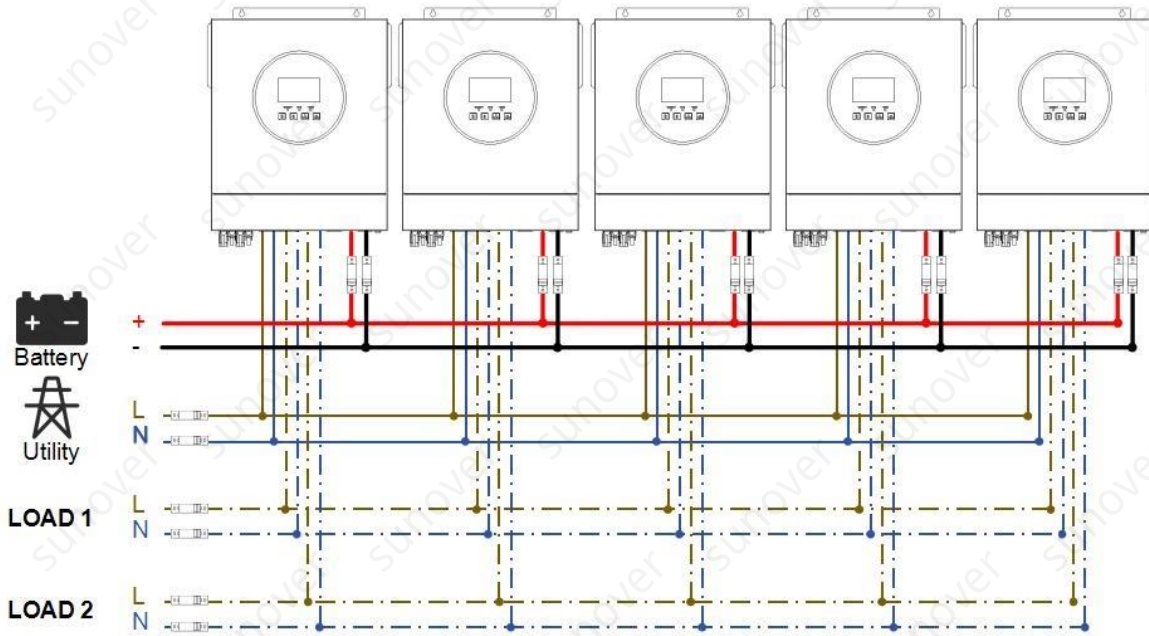

Communication Connection

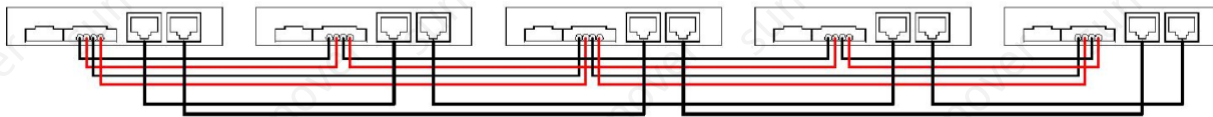

5.Six inverters in parallel :

Power Connection:

NOTE: The following picture only for your reference. It is subject to actual goods to be received.

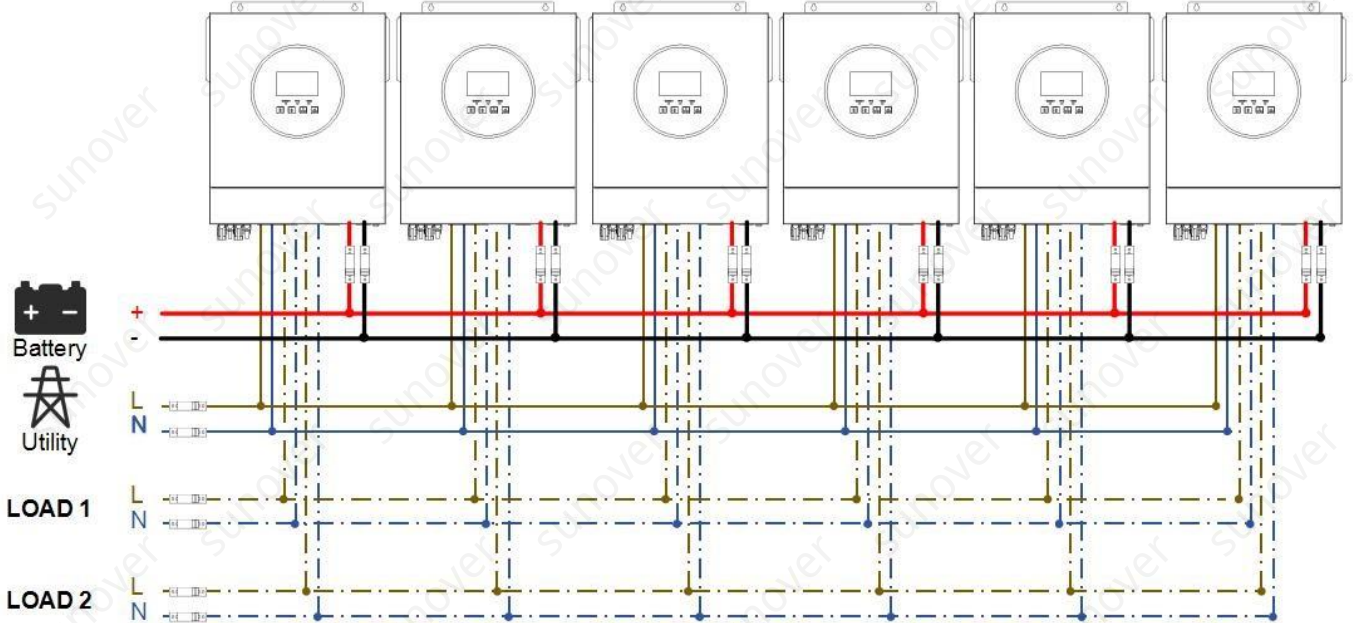

Communication Connection

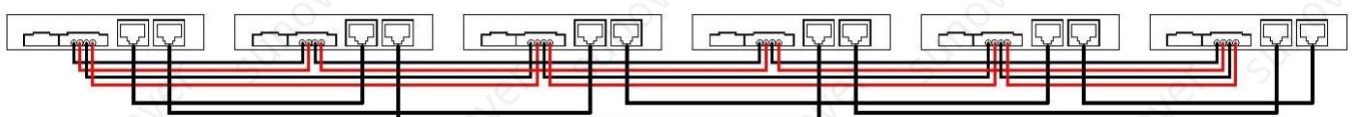

6.4 Matters Needing Attention In Three-phase Parallel Operation

1. Parallel operation in Three phase with up to 6 units.
2. **WARNING:** It's required to connect battery for parallel operation, it is forbidden to use parallel without batteries.
3. **WARNING:** It is forbidden for inverter to share the same solar panel group.
4. **WARNING:** Make sure all cables are of the same length, Otherwise, there will be voltage difference. between inverter and battery to cause parallel inverters not working.
5. Set the parameters of each inverter independently (working mode, three- phase parallel function and set A/B/C phase sequence).

WARNING: When working in parallel, the working mode of each inverter must be the same working mode, output frequency.

6. After setting the parameters, turn on each inverter in turn.
7. **WARNING:** When running in parallel, all inverters must share the battery pack.
8. **WARNING:** Do not connect the current sharing cable between the inverters which are in different phase. Otherwise ,it may damage inverters .

6.5 Three-phase Parallel Operation Cable Connection

1. One inverters in each phase:

Power Connection:

NOTE: The following picture only for your reference. It is subject to actual goods to be received.

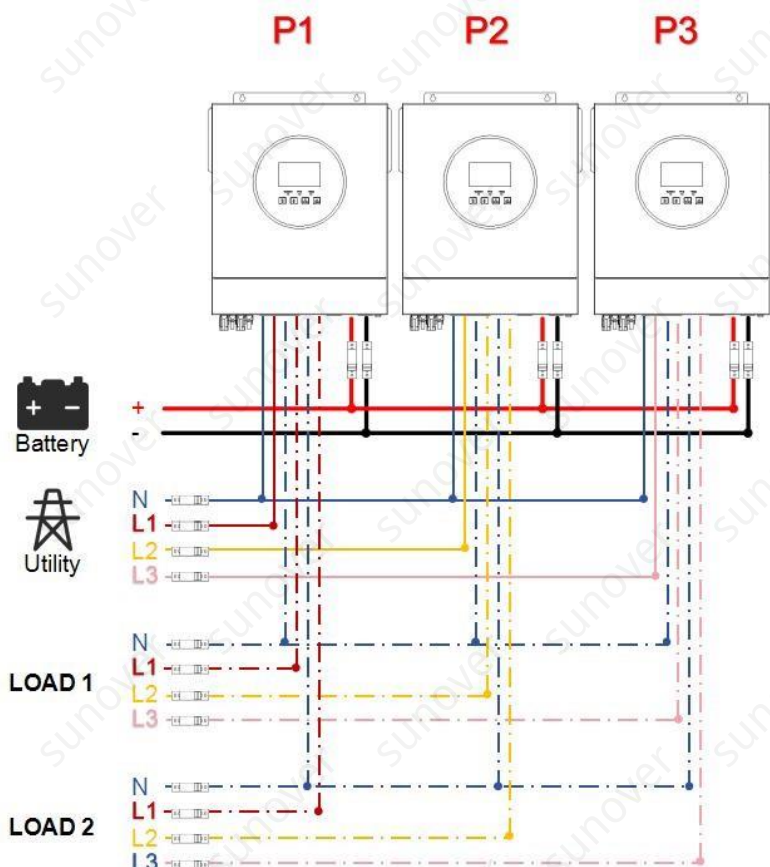

NOTE: P1: A-phase, P2: B-phase, P3: C-phase.

Communication Connection

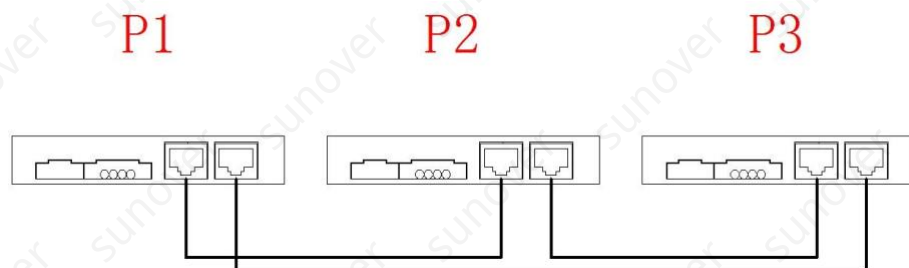

2. Two inverters in each phase:

Power Connection:

NOTE: The following picture only for your reference. It is subject to actual goods to be received.

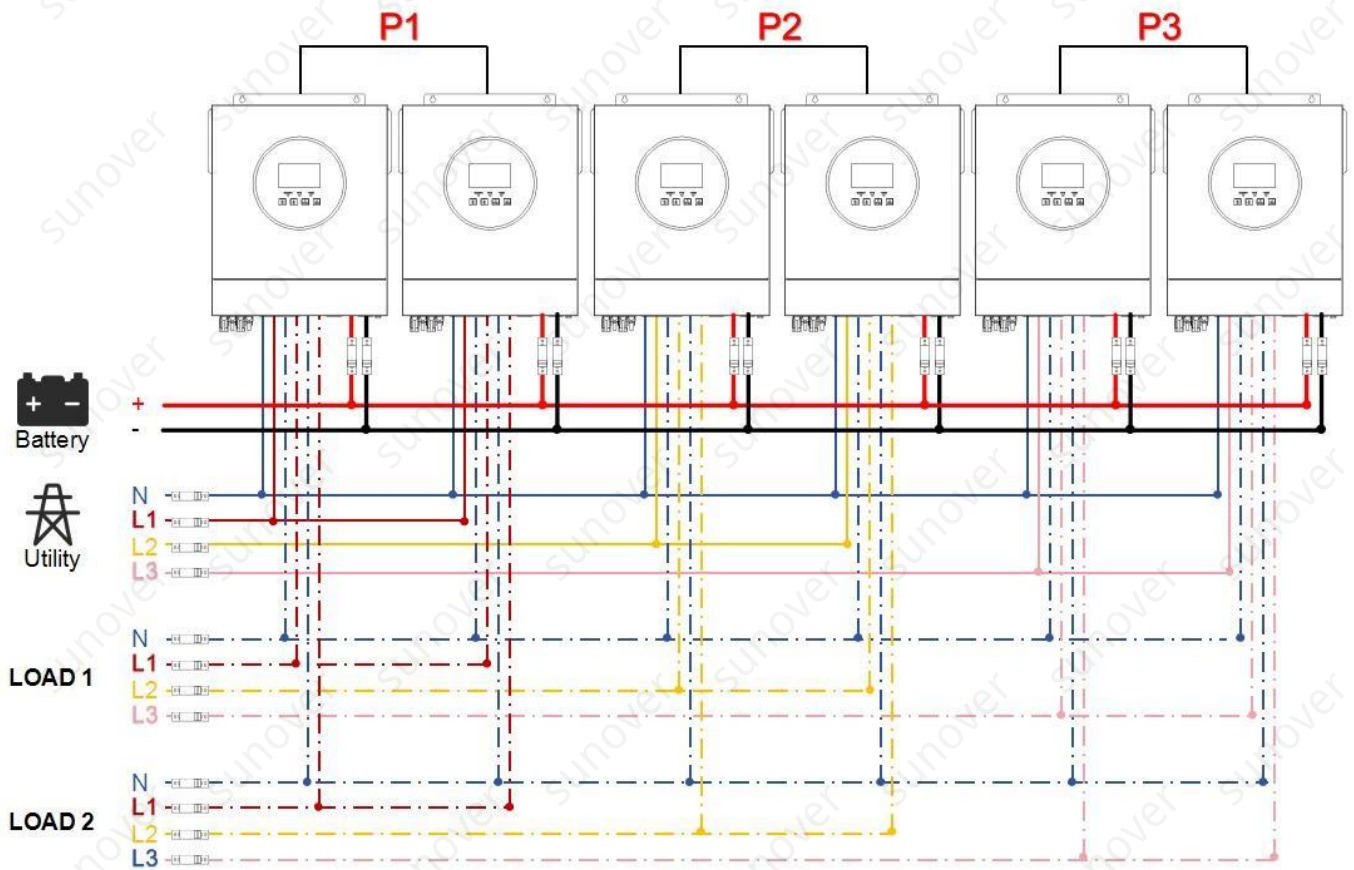

NOTE: P1: A-phase, P2: B-phase, P3: C-phase. Communication Connection

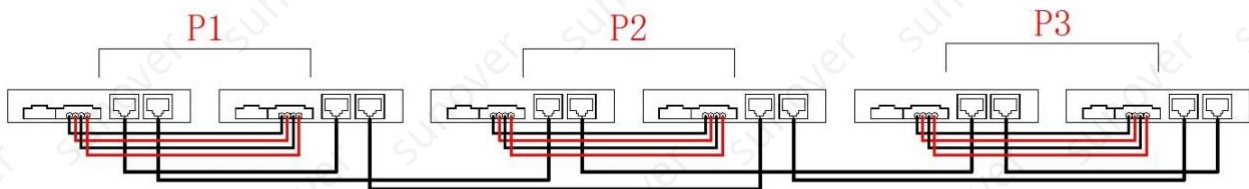

3. Four inverters in one phase and one inverter for the other two phases: Power Connection:

NOTE: The following picture only for your reference. It is subject to actual goods to be

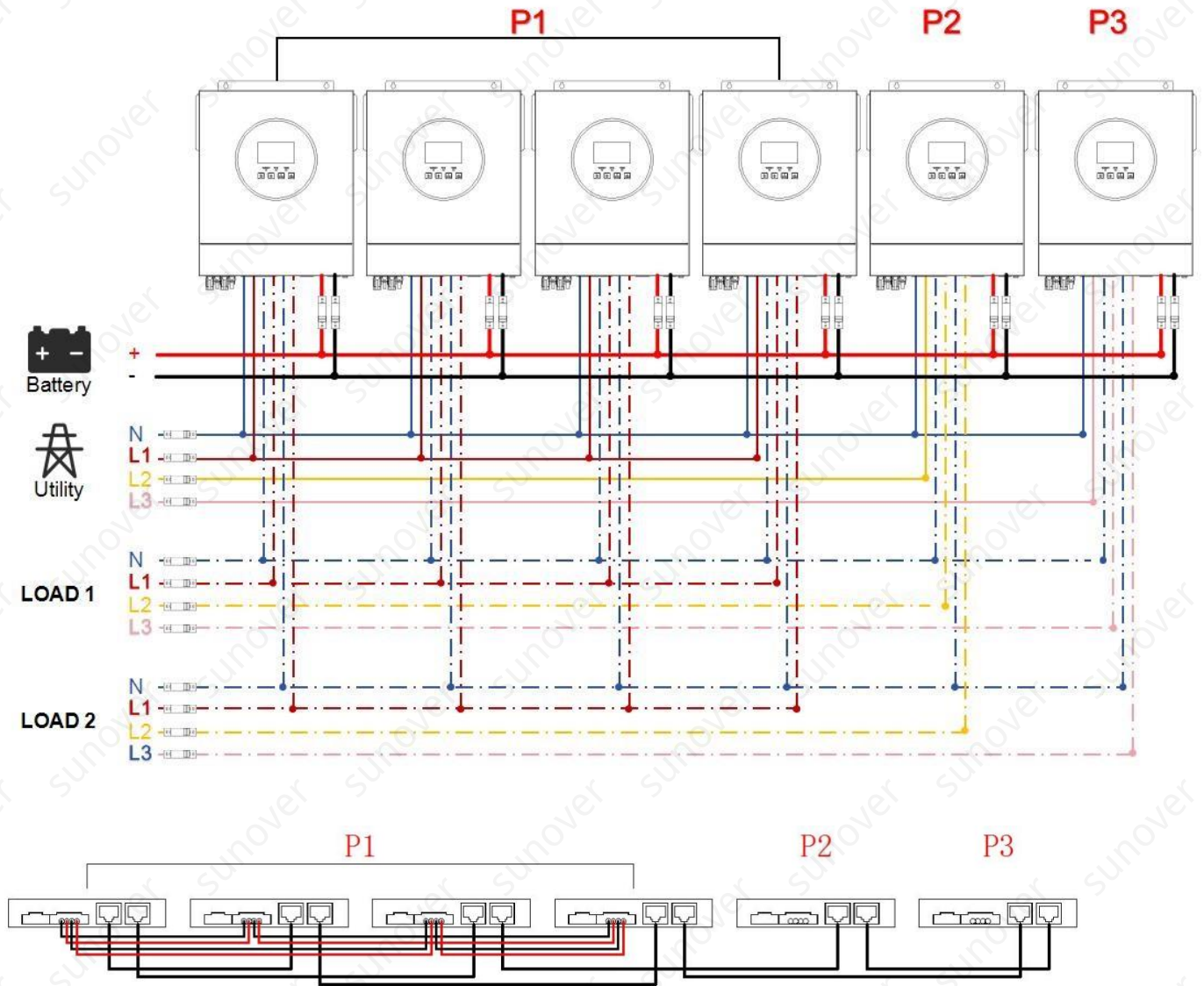

received.

NOTE:P1: A-phase, P2: B-phase, P3: C-phase. Communication

Connection

4.Three inverters in one phase, two inverters in second phase and one inverter for the third phase:

Power Connection:

NOTE: The following picture only for your reference. It is subject to actual goods to be received.

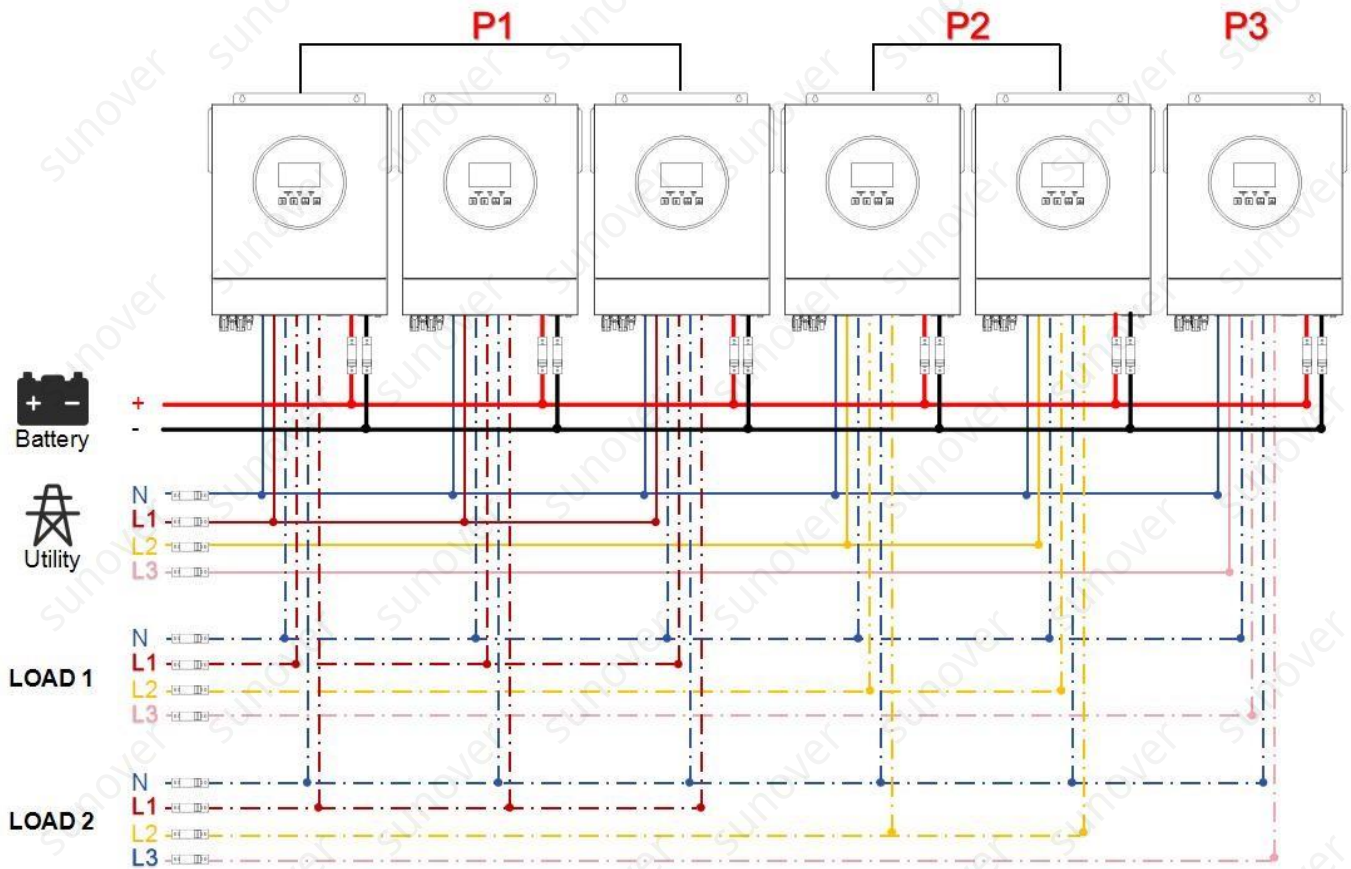

NOTE:P1: A-phase, P2: B-phase, P3: C-phase. Communication

Connection

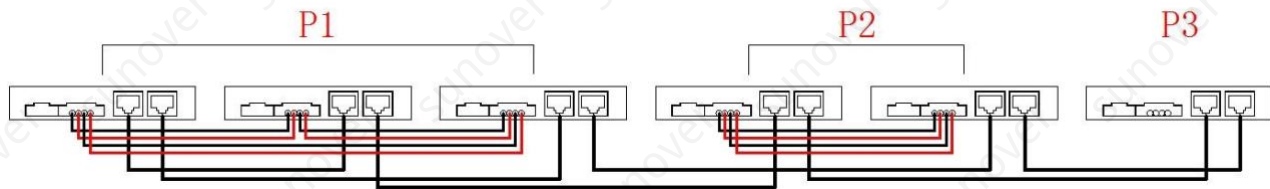

5. Three inverters in one phase and only one inverter for the remaining two phases:

Power Connection:

NOTE: The following picture only for your reference. It is subject to actual goods to be

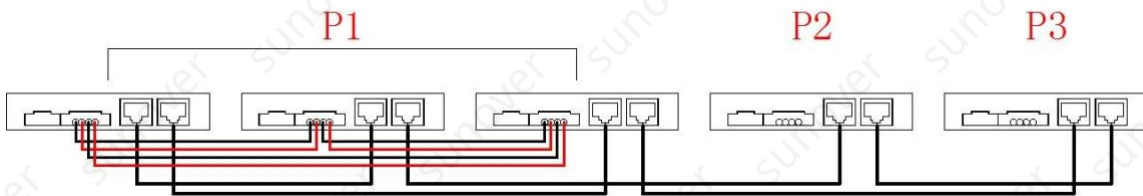

received.

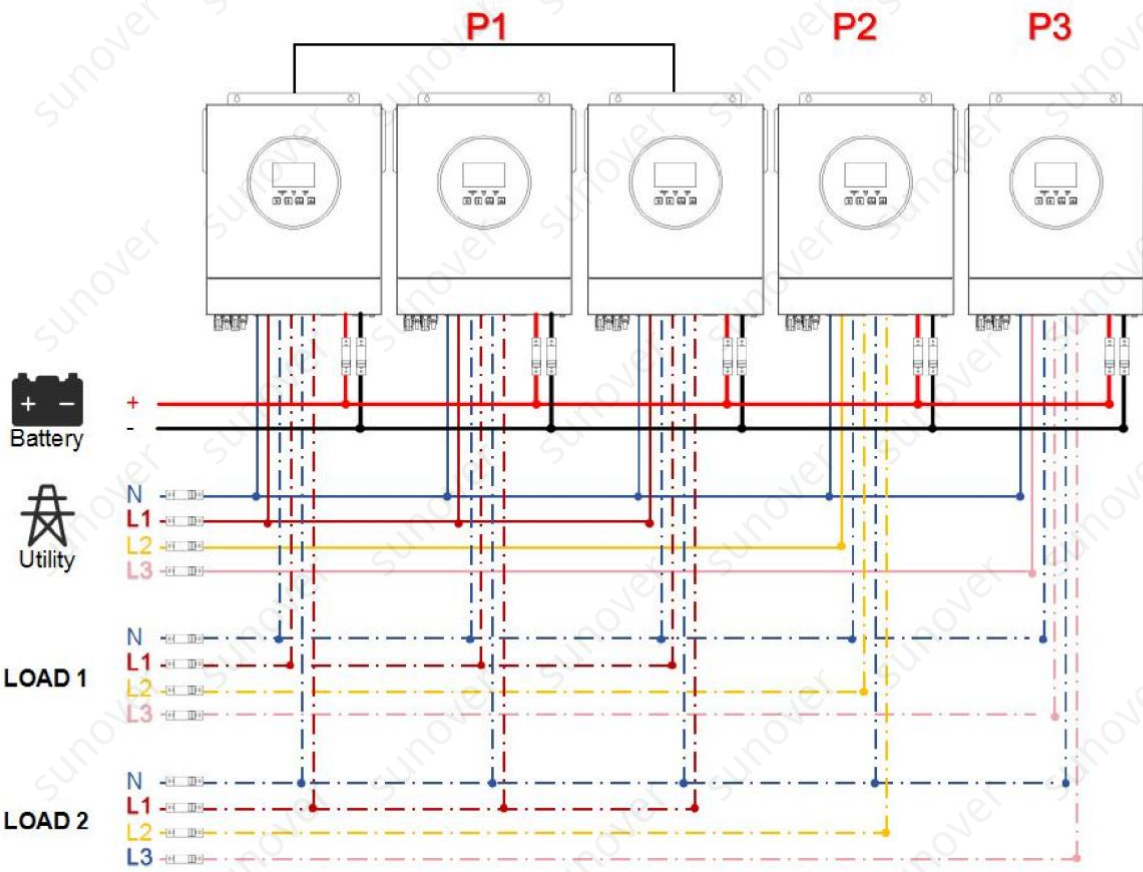

NOTE: P1: A-phase, P2: B-phase, P3: C-phase. Communication Connection

received.

6. Two inverters in two phases and only one inverter for the remaining phase: Power

Connection:

NOTE: The following picture only for your reference. It is subject to actual goods to be

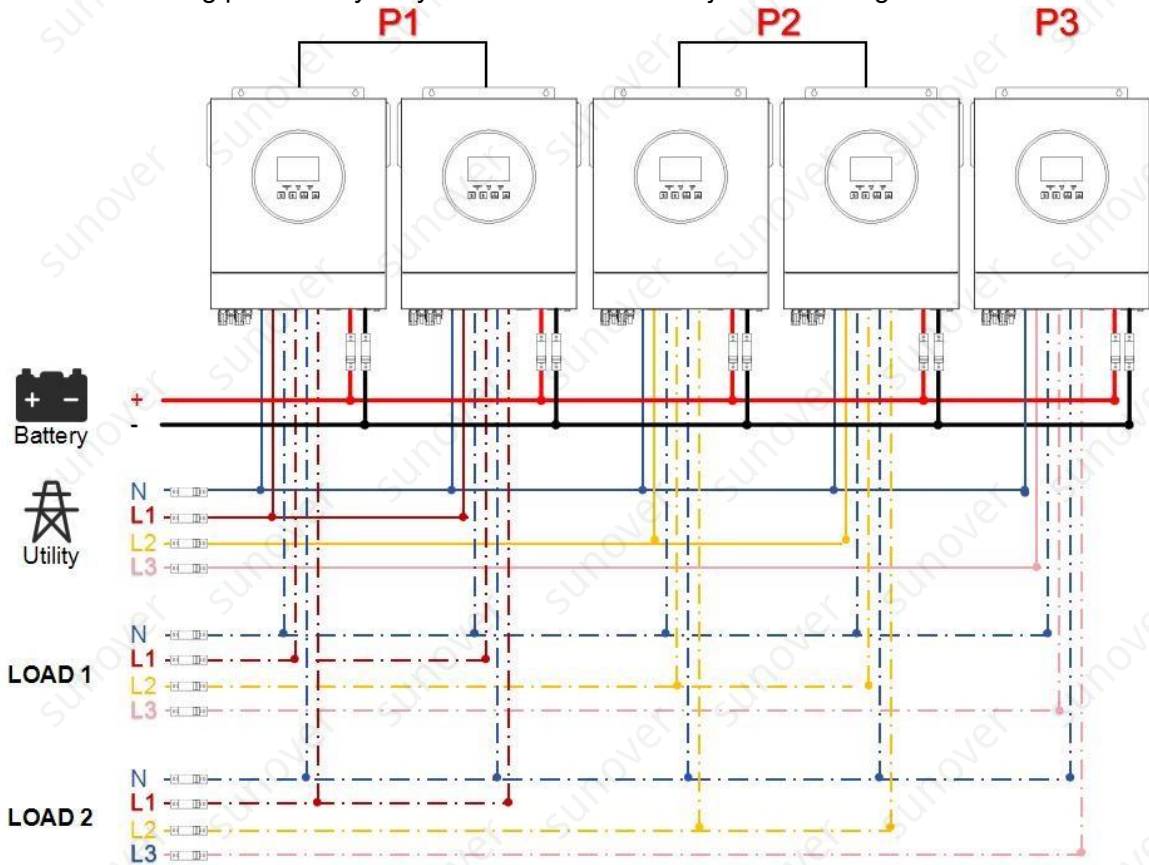

NOTE: P1: A-phase, P2: B-phase, P3: C-phase. Communication

Connection

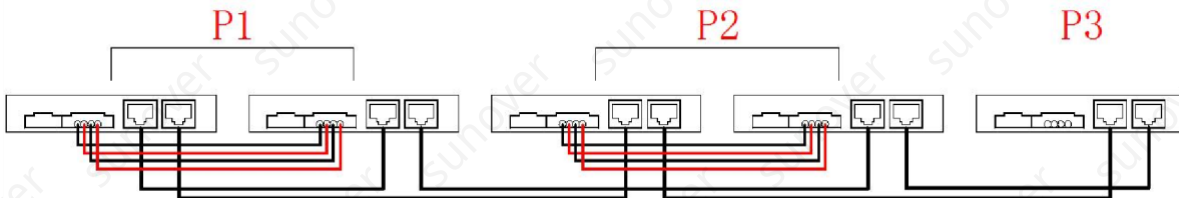

7. Two inverters in one phase and only one inverter for the remaining phases: Power

Connection:

NOTE: The following picture only for your reference. It is subject to actual goods to be

received.

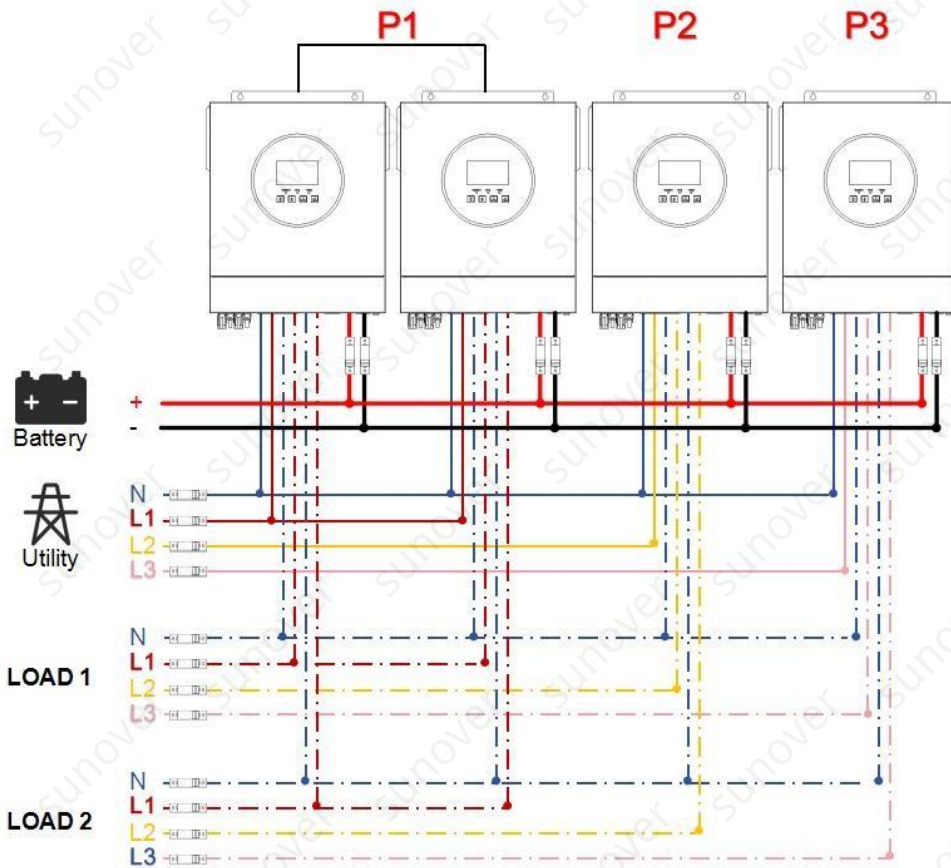

NOTE:P1: A-phase, P2: B-phase, P3: C-phase. Communication Connection

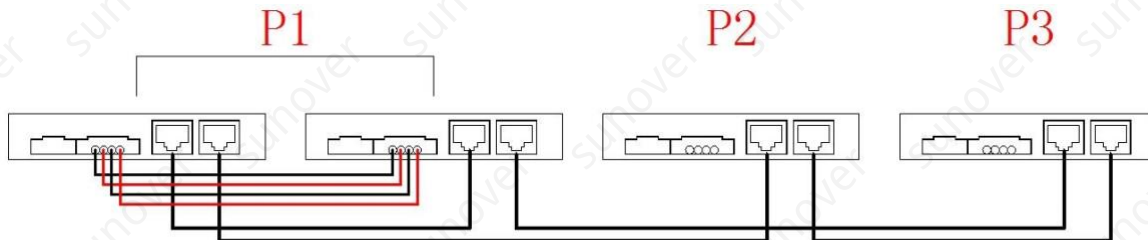

6.6 Matter need attention of the parallel installation

1. PV Input Range

The inverter is designed to accept a photovoltaic input voltage range. It is recommended that the series voltage of the PV panels should not exceed 350V. This ensures the optimal operation and safety of the system.

2. Three-Phase Output Using Three Single-Phase Inverters

To achieve a three-phase output using three single-phase inverters, the following guidelines must be adhered to:

2.1 PV Panel Quantity and Configuration Consistency

- It is crucial that each inverter is connected to an identical number of photovoltaic panels. The configuration of the panels, including the total number and arrangement, must be the same for each inverter. This ensures balanced power generation and distribution across all three phases.

2.2 Parallel Communication Connection

- The three inverters must be properly interconnected through their parallel communication ports. This can be achieved by connecting the communication ports in a "hand-in-hand" manner. This setup ensures synchronized operation and proper phase alignment, which is necessary for stable three-phase power output.

2.3 Neutral Line Requirement

- When configuring the system for 3-phase output, it is mandatory to have neutral line in the load. The system does not support loads without neutral line. This requirement is crucial for ensuring proper operation and safety, as the neutral line provides a reference point for the three-phase power system.

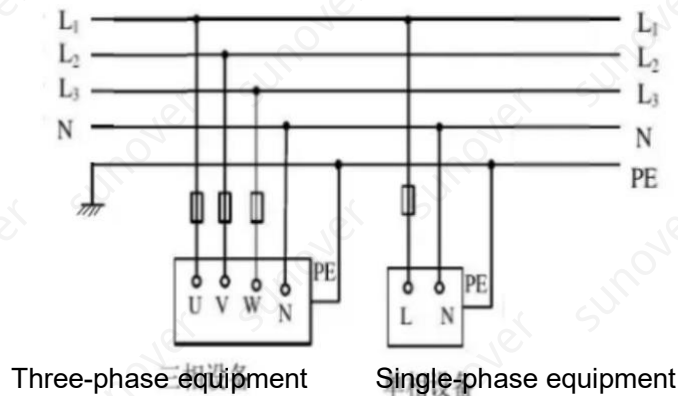

Load type must use the neutral line (N) as shown in the figure

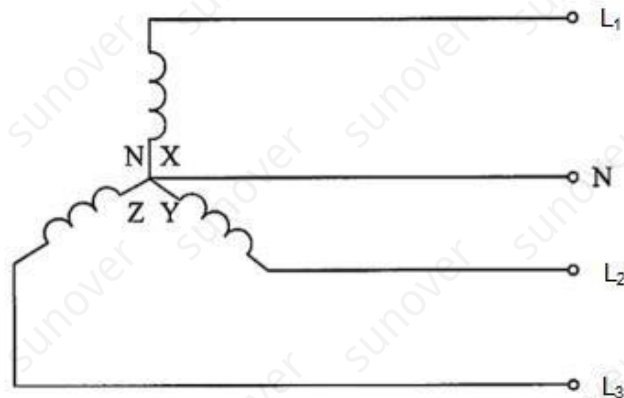

If it is a star connection, the neutral line must be used

3. Detailed Inverter and Battery BMS Communication Setup Steps

To establish communication between the inverter and the battery management system (BMS), follow these steps:

- 1. Connect the Communication Cable:**
 - Use the designated communication cable to connect the inverter's communication port to the battery BMS port. Ensure the cable is securely connected and that the ports are correctly matched. PIN definition.
- 2. Configure Inverter Communication Settings:**
 - Access the inverter's user interface, either via the display panel or a connected device (such as a laptop or mobile device).
 - Navigate to the settings menu and select the communication settings option.
 - Set the communication protocol to match the protocol used by the BMS (e.g., CAN, RS485, etc.). Refer to the BMS user manual for the correct protocol and baud rate settings.
- 3. Address and ID Configuration:**
 - Assign a unique communication address or ID to the inverter if required. This step is essential if multiple inverters are being used in parallel or in systems with multiple devices.
- 4. BMS Settings Verification:**
 - Ensure the BMS is set up to recognize the inverter's communication protocol and address. This may involve setting the BMS to "inverter mode" or selecting the appropriate communication settings.
- 5. System Testing:**
 - Once all settings are configured, perform a system test to verify communication between the inverter and the BMS. This can usually be done through a diagnostic tool or by checking for status indicators on the inverter and BMS.
- 6. Monitoring and Adjustment:**
 - Monitor the system to ensure that the inverter and BMS are communicating correctly and that data is being accurately exchanged. If there are any communication issues, review the settings and connections, and make necessary adjustments.

7. Faults Code

Fault Code	Fault Event
01	Fan is locked
02	Over temperature
03	Battery voltage is too high
04	Battery voltage is too low
05	Output short circuited.
06	Output voltage is too high.
07	Overload time out
08	Bus voltage is too high
09	Bus soft start failed
24	PV over temperature
52	Bus voltage is too low
53	Inverter soft start failed
55	Over DC voltage in AC output
57	Current sensor failed
58	Output voltage is too low

8. Warning Code

Warning Code	Warning Event
01	Fan is locked
02	Over temperature
03	Battery is over-charged
04	Low battery
07	Overload
10	Output power derating
08	Discharge over current

15	PV energy is low
16	High AC input (>280VAC) during BUS soft start
21	PV low voltage
22	PV over voltage

9. Parallel Faults Code

Fault Code	Fault Event
60	Power feedback protection
71	Firmware version inconsistent
72	Current sharing fault
73	Output voltage different
80	CAN fault
81	Host loss
82	Synchronization loss
83	Battery voltage detected different
84	AC input voltage and frequency detected different
85	AC output current unbalance
86	AC output mode setting is different

10. Trouble Shooting

Problem	LCD/LED/Buzzer	Possible cause	What to do
Unit shuts down automatically during start up process	LCD/LED and buzzer will be active then complete off	The battery voltage is too low	1.Re-charge battery. 2.Replace battery
No response after power on	No indication	1.The battery voltage is too low. 2.Internal fuse tripped	1.Contact repair center for replacing the fuse. 2.Re-charge battery. 3.Replace battery.
Mains exist but the unit works in battery mode	Input voltage is displayed as '0' on the LCD and green LED is flashing	Input protector is triggered	Check if AC breaker is turned on and AC wiring is connected well.
	LED is flashing	Insufficient quality of AC power(grid or generator)	1.Check if AC wires are too thin and/or too long. 2.Check if generator (if applied) is working well or if input voltage range setting is correct.
When the unit is turned on, internal relay is switched on and off repeatedly	LCD display and LED flashing	Set "Solar First" as the priority of output source.	Change output source priority to utility first.
Buzzer beeps continuously and red LED is on	Fault code 01	Fan fault	Replace the fan
	Fault code 02	Internal temperature of inverter component is over 85°C	Check whether the environment around the equipment well ventilated
	Fault code 03	The battery voltage is too high	Check if spec and quantity of batteries are meet requirements
		battery is over charged	Return to repair center
	Fault code 04	The battery voltage is too low	1.The battery is dead, please charge the battery immediately 2.Check the battery for damage
	Fault code 05	Output short circuited	1.Check that the output cable is connected 2.Return to the maintenance center

Fault code 06/58	Output abnormal (Inverter voltage range 180-260VAC)	Return to the maintenance center
Fault code 07	Overload error , the inverter is overload 110% and overload time reaches the upper limit	Reduce load

Buzzer beeps continuously and red LED is on			
	Fault code 10	Over current or surge	Remove abnormal load or check PV input
	Fault code 11	The configuration of the solar panel is higher than the PV input voltage required by the inverter	Remove the excess solar panels
	Fault code 13	Battery discharge over current	Please check whether the discharge current of Item 40 is lower than the discharge current of the inverter
	Fault code 52/55	Internal fault of inverter	Return to the maintenance center
	Fault code 60	Power feedback protection	1.Restart the inverter. 2.Check if L/N cables are not connected reversely in all inverters. 3.For parallel system in single phase ,make sure the sharing are connected in all inverters. for supporting three-phase system, make sure the sharing cables are connected in the inverters in the same phase. and disconnected in the inverters in different phase.
	Fault code 71	Firmware version inconsistent	1.Update all inverter firmware to the same version 2.If the problem remains please contact your installer.

	Fault code 72	The output current of each inverter is different	<ol style="list-style-type: none"> check if sharing cables are connected well and restart the inverter. if the problem remains please contact your installer.
	Fault code 73	AC output voltage setting is different	Check whether the output voltage of each inverter are set the same

Buzzer beeps continuously and red LED is on	Fault code 80	CAN data loss	<ol style="list-style-type: none"> Check if communication cables are connected well and restart the inverter If the problem remains, please contact your installer.
	Fault code 81	Host data loss(only for three-phase parallel)	
	Fault code 82	Synchronization data loss	
	Fault code 83	The battery voltage of each inverter is not the same.	<ol style="list-style-type: none"> Make sure all inverters share same groups of batteries together. Remove all loads and disconnect AC input and PV input. Then, check battery voltage of all inverters. If the values from all inverters are close, please check if all battery cables are the same length and same material type. Otherwise, please contact your installer to provide SOP to calibrate battery voltage of each inverter. If the problem still remains, please contact your installer.
	Fault code 84	AC input voltage and frequency detected different	Check whether the input voltage and frequency of each inverter are set the same

	Fault code 85	AC output current unbalance	<ol style="list-style-type: none"> 1.Restart the inverter 2.Remove some excessive loads and re-check load information from LCD of inverters. If the values are different, please check if AC input and output cables are in the same length and material type.
	Fault code 86	AC output mode setting is different.	<ol style="list-style-type: none"> 1.Check whether it is set to parallel mode 2.Return to the maintenance center

11. Specifications

11.1 Line Mode Specifications

MODEL	10KW48Vdc
Input Voltage Waveform	Sinusoidal (utility or generator)
Nominal Input Voltage	230Vac
Low Loss Voltage	170Vac±7Vac (narrow range) 90Vac±7Vac (wide range)
Low Loss Return Voltage	180Vac±7Vac (narrow range) 100Vac±7Vac (wide range)
High Loss Voltage	280Vac±7Vac
High Loss Return Voltage	270Vac±7Vac
Max AC Input Voltage	300Vac
Max AC Input Current	60A
Nominal Input Frequency	50Hz / 60Hz (Auto detection)
Low Loss Frequency	40±1Hz
Low Loss Return Frequency	42±1Hz
High Loss Frequency	65±1Hz
High Loss Return Frequency	63±1Hz

Output Short Circuit Protection	Line mode: Circuit Breaker (70A) Battery mode: Electronic Circuits
Efficiency (Line Mode)	>95% (Rated R load, battery full charged)
Transfer Time	10ms typical (narrow range) 20ms typical (wide range)
Output power de-rating: When AC input voltage under 170V the output power will be de- rated.	<p>Output Power</p> <p>Rated Power</p> <p>50% Power</p> <p>90V 170V 280V Input voltage</p>

11.2 Inverter Mode Specifications

MODEL	10KW
Rated Output Power	10000W
Output Voltage Waveform	Pure Sine Wave
Output Voltage Regulation	230Vac±5%
Output Frequency	60Hz or 50Hz
Max. peak Efficiency	93%
Overload Protection	5s@≥150% load; 10s@110%~ 150% load
Surge Capacity	2* rated power for 5 seconds
Low DC Cut-off Voltage	42Vdc
Nominal DC Input Voltage	48Vdc
Cold Start Voltage	46.0Vdc

Low DC Warning Voltage @ load < 20% @ 20% ≤ load < 50% @ load ≥ 50%	44.0Vdc 42.8Vdc 40.4Vdc
Low DC Warning Return Voltage @ load < 20% @ 20% ≤ load < 50% @ load ≥ 50%	48.0Vdc 44.8Vdc 42.4Vdc
Low DC Cut-off Voltage @ load < 20% @ 20% ≤ load < 50% @ load ≥ 50%	44.0Vdc 40.8Vdc 38.4Vdc
High DC Recovery Voltage	61Vdc
High DC Cut-off Voltage	63Vdc
Communication	RS232 or RS485 or CAN ,WIFI(option)

Note:

- 1. RS485,CAN communication share the same port ,so it can't be used at the same time.**
- 2. WIFI needs to be equipped with a data logger before it can be used.**

11.3 Charge Mode Specifications

Utility Charging Mode		
MODEL	10KW	
Charging Current @ Nominal Input Voltage	120A	
Bulk charging Voltage	Flooded Battery	58.4Vdc
	AGM / Gel Battery	56.4Vdc
Floating Charging Voltage	54.0Vdc	
Overcharge Protection	63.0Vdc	
Charging Algorithm	3-Step	

Charging Curve

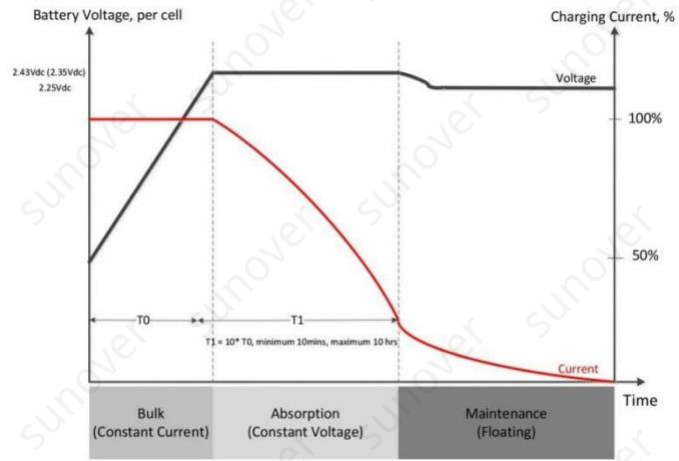

Solar Input

MODEL	10KW
Max. PV Array Power	5000*2
Max. PV Array Open Circuit Voltage	500Vdc
Nominal PV Voltage	320Vdc
PV Array MPPT Voltage Range	60Vdc~450Vdc
Max. Input Current	15A*2

11.4 General Specifications

MODEL	10KW
Safety Certification	CE
Operating Temperature Range	- 10°C to 50°C
Storage temperature	- 15°C~ 60°C
Humidity	5% to 95% Relative Humidity (Non-condensing)
Dimension (L*W*H), mm	541*135.5* 400
Net Weight, kg	19.4

12. Installation Dimension Drawing

(unit:mm)

NOTE: The following picture is only a schematic diagram of the equipment. If the actual machine structure does not conform to this drawing due to structural upgrades, it may not be notified in time.

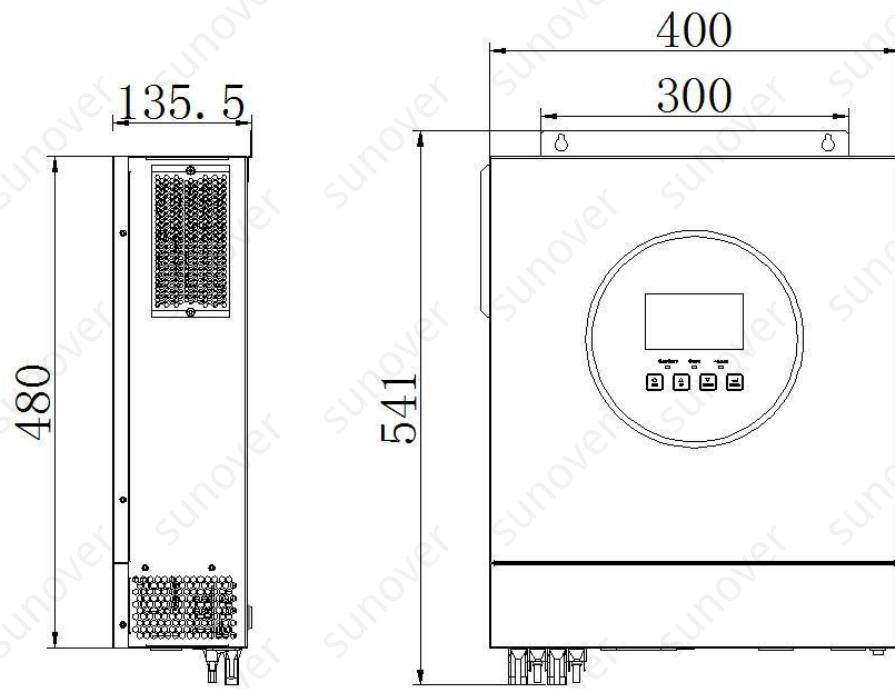

614.C0559B-00