

USER MANUAL

VOLANT PRO-H 4-6KW INVERTER



Contents

1. ABOUT THIS MANUAL	1
1.1 Purpose	1
1.2 Scope	1
1.3 Safety instructions	1
2. Introduction	1
2.1 Features	1
2.2 Basic System Architecture	2
2.3 Product Overview	3
3. INSTALLATION	4
3.1 Unpacking and Inspection	4
3.2 Preparation	4
3.3 Mounting the Unit	5
3.4 Battery Connection	5
3.5 AC Input / Output Connection	7
3.6 PV Connection	8
3.7 Final Assembly	10
3.8 RS232 Communication Connection	11
3.9 Dry Contact Signal	11
3.10 Wi-Fi Connection(Optional)	11
4. OPERATION	12
4.1 Power ON/OFF	12
4.2 Operation and Display Panel	12
4.3 LCD Display Icons	13
4.4 LCD Setting	14
4.5 Parallel function operation instructions (Optional)	19
4.6 Battery Equalization Description	30
4.7 Fault Reference Code	31
4.8 Warning Indicator	32
4.9 Parallel Faults Code	32
5. TROUBLE SHOOTING	34
6. SPECIFICATIONS	37
Table 1 Line Mode Specifications	37
Table 2 Inverter Mode Specifications	38
Table 3 Charge Mode Specifications	39
Table 4 General Specifications	39
7. INSTALLATION DIMENSION DRAWING	40

1. ABOUT THIS MANUAL

1.1 Purpose

This manual describes the assembly, installation, operation and troubleshooting of this unit.

Please read this manual carefully before installations and operations. Keep this manual for future reference.

1.2 Scope

This manual provides safety guidelines of installation, and the information on tools and wiring.

1.3 Safety instructions



WARNING: All safety instructions in this document must be read, understood and followed.

Failure to follow these instructions will result in death or serious injury.

1. Before using the unit, read all instructions and cautionary markings on the unit, the batteries and all appropriate sections of this manual.
2. **CAUTION** --To reduce risk of injury, charge only deep-cycle type rechargeable batteries. Other types of batteries may burst, causing personal injury and damage.
3. Do not disassemble the unit. Take it to a qualified service center when service or repair is required. Incorrect re-assembly may result in a risk of electric shock or fire.
4. To reduce risk of electric shock, disconnect all wirings before attempting any maintenance or cleaning. Turning off the unit will not reduce this risk.
5. **CAUTION** – Only qualified personnel can install this device with battery.
6. **NEVER** charge a frozen battery.
7. For optimum operation of this inverter/charger, please follow required spec to select appropriate cable size. It's very important to correctly operate this inverter/charger.
8. Be very cautious when working with metal tools on or around batteries. A potential risk exists to drop a tool to spark or short circuit batteries or other electrical parts and could cause an explosion.
9. Please strictly follow installation procedure when you want to disconnect AC or DC terminals. Please refer to **INSTALLATION** section of this manual for the details.
10. One piece of 200A fuse is provided as over-current protection for the battery supply.
11. **GROUNDING INSTRUCTIONS** -This inverter/charger should be connected to a permanent grounded wiring system. Be sure to comply with local requirements and regulation to install this inverter.
12. **NEVER** cause AC output and DC input short circuited. Do **NOT** connect to the mains when DC input short circuits.
13. **Warning!!** Only qualified service persons are able to service this device. If errors still persist after following troubleshooting table, please send this inverter/charger back to local dealer or service center for maintenance.
14. **WARNING:** Because this inverter is non-isolated, only three types of PV modules are acceptable: single crystalline, poly crystalline with class A-rated and CIGS modules. To avoid any malfunction, do not connect any PV modules with possible current leakage to the inverter. For example, grounded PV modules will cause current leakage to the inverter. When using CIGS modules, please be sure **NO** grounding.
15. **CAUTION:** It's requested to use PV junction box with surge protection. Otherwise, it will cause damage on inverter when lightning occurs on PV modules.

2. Introduction

This is a multi-function inverter, combining functions of inverter, solar charger and battery charger to offer uninterruptible power support in a single package. The comprehensive LCD display offers user-configurable and easy-accessible button operations such as battery charging current, AC or solar charging priority, and acceptable input voltage based on different applications.

2.1 Features

1. Pure sine wave inverter
2. Configurable input voltage ranges for home appliances and personal computers via LCD control panel
3. Configurable battery charging current based on applications via LCD control panel
4. Configurable AC/Solar Charger priority via LCD control panel
5. Compatible to utility mains or generator power
6. Auto restart while AC is recovering
7. Overload / Over temperature / short circuit protection
8. Smart battery charger design for optimized battery performance
9. Cold start function
10. Second output can be controlled by battery voltage

2.2 Basic System Architecture

The following illustration shows basic application for this unit. It also required the following devices to have a complete running system:

- Generator or Utility mains.
- PV modules

Consult with your system integrator for other possible system architectures depending on your requirements.

This inverter can power various appliances in home or office environment, including motor-type appliances such as tube light, fan, refrigerator and air conditioners.

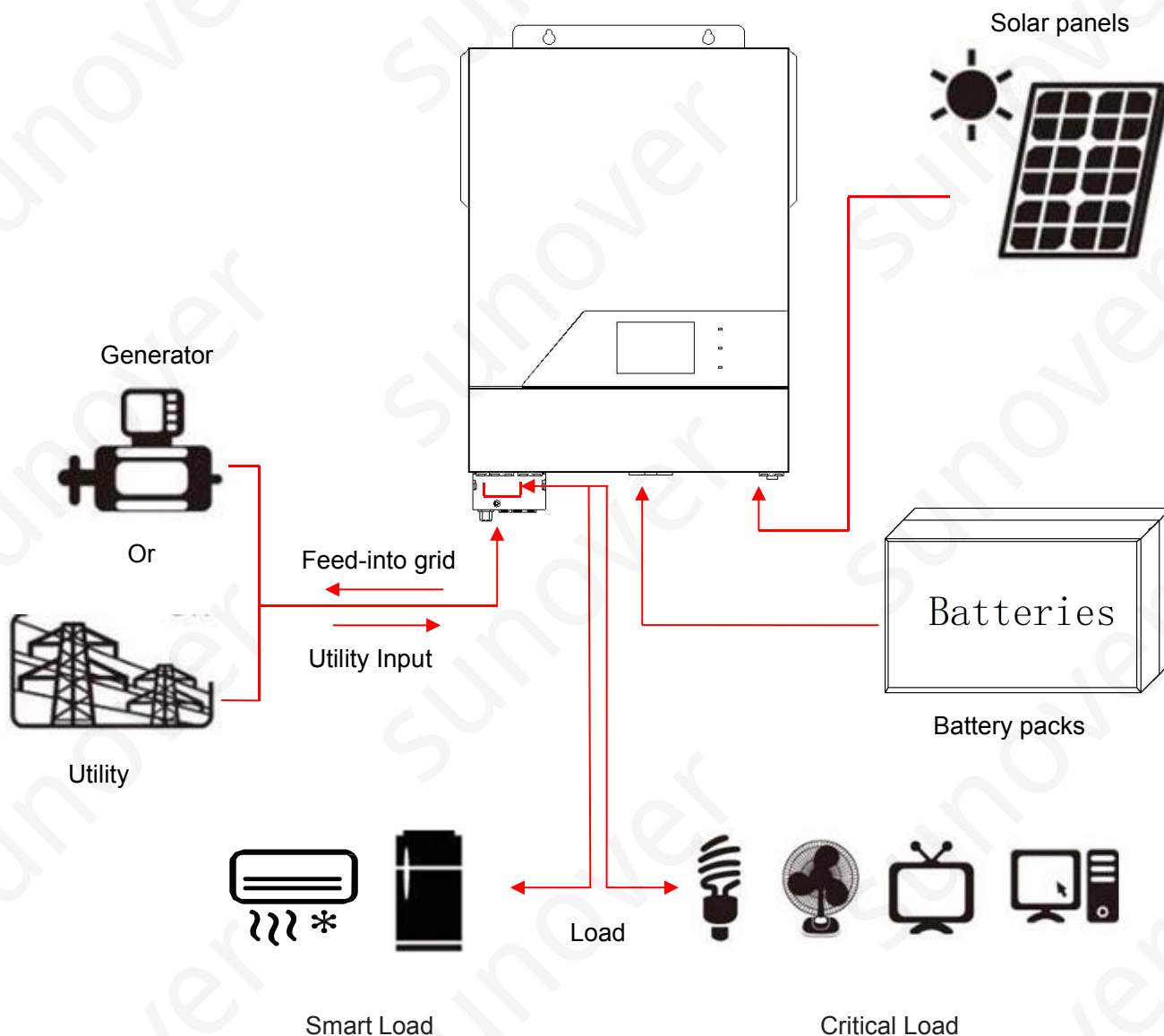
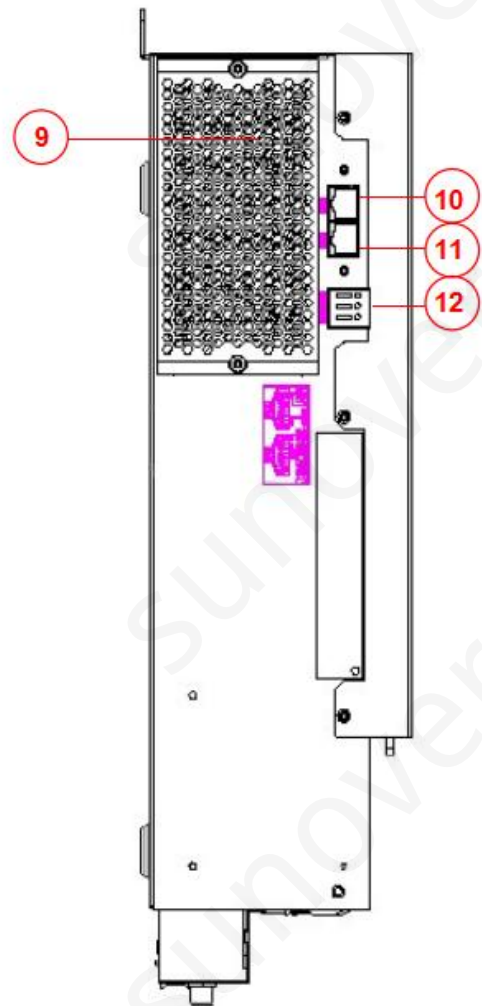
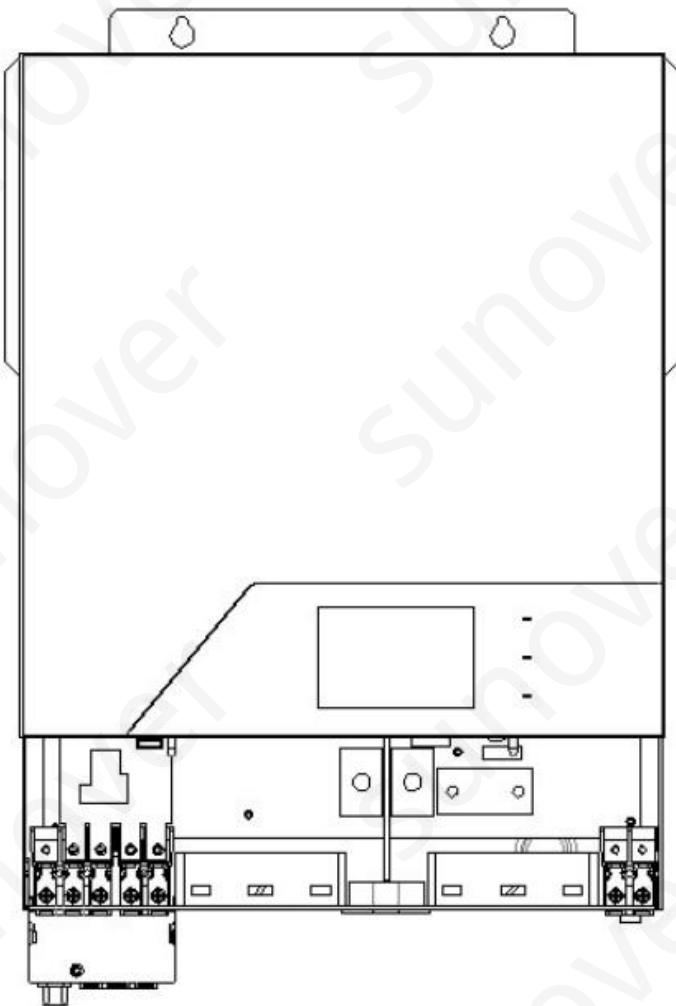
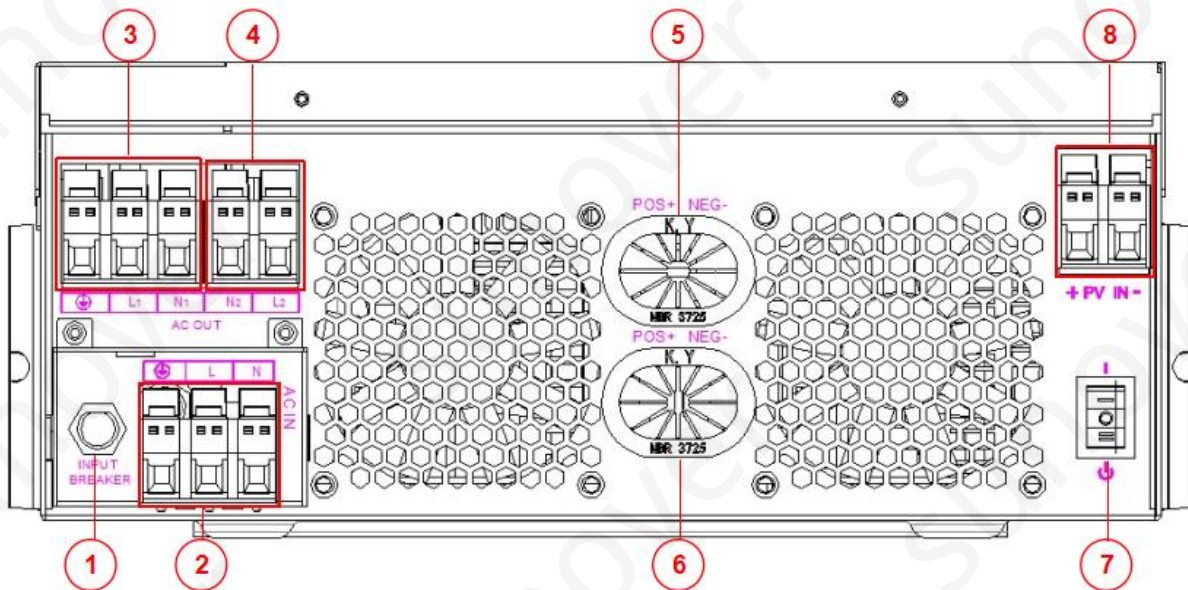

Figure 1 Hybrid Power System

2.3 Product Overview



- | | |
|--|--------------------------------------|
| 1. Breaker | 7. Power On/off Switch |
| 2. AC Input Terminal | 8. PV Input Terminal |
| 3. AC Output 1 Terminal | 9. Dust Cover |
| 4. AC Output 2 Terminal(Second output) | 10. RS232 Communication Port |
| 5. Battery Input 2 | 11. BMS Communication Port(Optional) |
| 6. Battery Input 1 | 12. Dry Contact Connector |

Note: RS485,CAN communication share the same port ,so it can't be used at the same time.

Communication port definition:

RS232	1:RXD , 2:TXD,8:GND
RS485/ CAN	1:485-B ,2.485-A 4:CAN-H,5:CAN-L

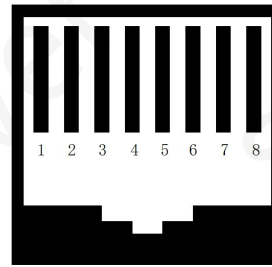

COMM

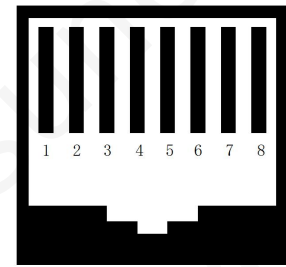

BMS

3. INSTALLATION

3.1 Unpacking and Inspection

Before installation, please inspect the unit. Be sure that everything in the package is not damaged. The following items inside of package would be received.

- ◆ The inverter x1
- ◆ User manual x 1
- ◆ Parallel communication cable x 1(No parallel machine ,No need)
- ◆ Current sharing cable x 1 (No parallel machine ,No need)

3.2 Preparation

Please remove the two screws on the cover of the device before opening it.

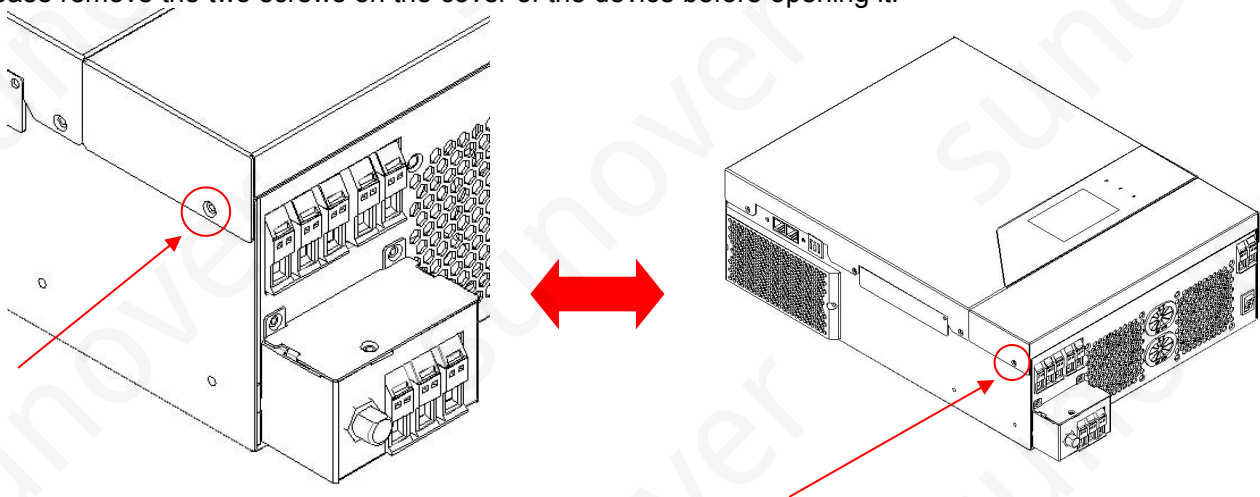

3.3 Mounting the Unit

Consider the below points before selecting where to install:

1. Do not mount the inverter on the surface of flammable construction materials.
2. Mount on the surface of solid material.
3. Install this inverter at a visible place in order to allow the LCD display to be read at all times.
4. For proper air circulation and heat dissipate, make sure there is 20 cm distance from the two side 50 cm distance from bottom of the unit.
5. The ambient temperature should be between -10°C and 50°C to ensure optimal operation.
6. The recommended installation position is to be adhered to the wall vertically.
7. Be sure to keep other objects and surfaces as shown in the diagram to guarantee sufficient heat dissipation and to have enough space for collecting wires.

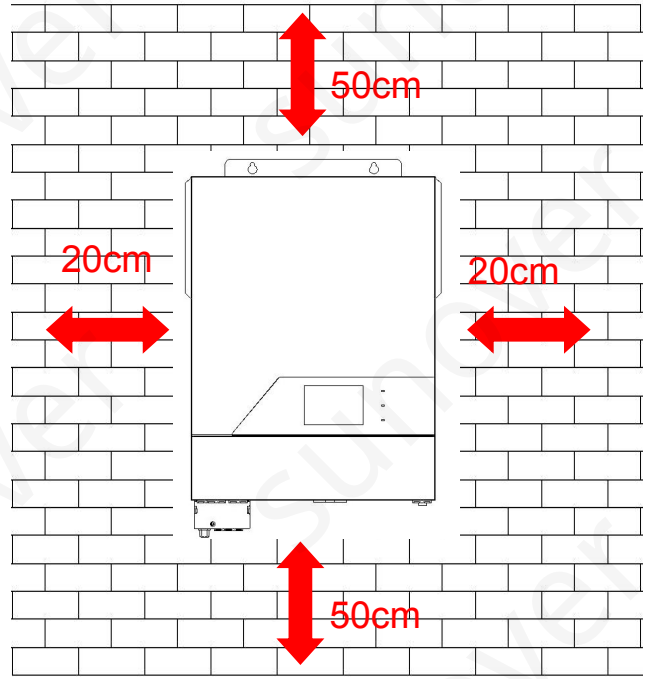

 **SUITABLE FOR MOUNTING ON CONCRETE OR OTHER NON-COMBUSTIBLE SURFACE ONLY**
Mounting the unit by screwing the three screws as shown below. It's recommended to use M4 or M5 screws.

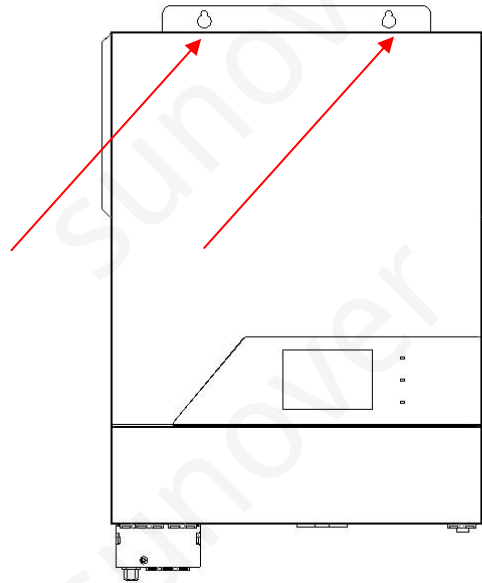

3.4 Battery Connection

CAUTION: For safety operation and regulation compliance, it's requested to install a separate DC over-current protector or disconnection device between battery and the inverter. It may not be necessary to have a disconnection device in some applications, however, it's still recommended to have over-current protection installed. Please refer to typical amperage as required.

WARNING! All wiring must be performed by a qualified electrical technician. **WARNING!** It's very important for system safety and efficient operation to use appropriate cables for battery connection. To reduce risk of injury, please use the proper recommended cable in the table below.

Recommended battery cable size:

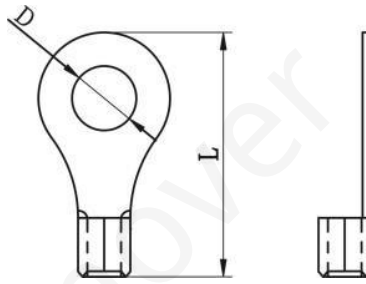

Ring terminal:

Model	Max. Discharge Current	AWG Cable	GB Cable mm ²	Ring Terminal Dimensions		Torsion force value
				D(mm)	L(mm)	
				4KW	190	
6KW	143	1*3AWG	1*35 ²			

Please take the following steps to implement battery connection:

1. Assemble the batteries according to the recommended battery cables and terminals. This cable applies only to the 4KW/6KW model.
2. Connect all battery packs as required. It is recommended that the 4K and 6K devices be connected to a battery with a capacity of at least 200AH.

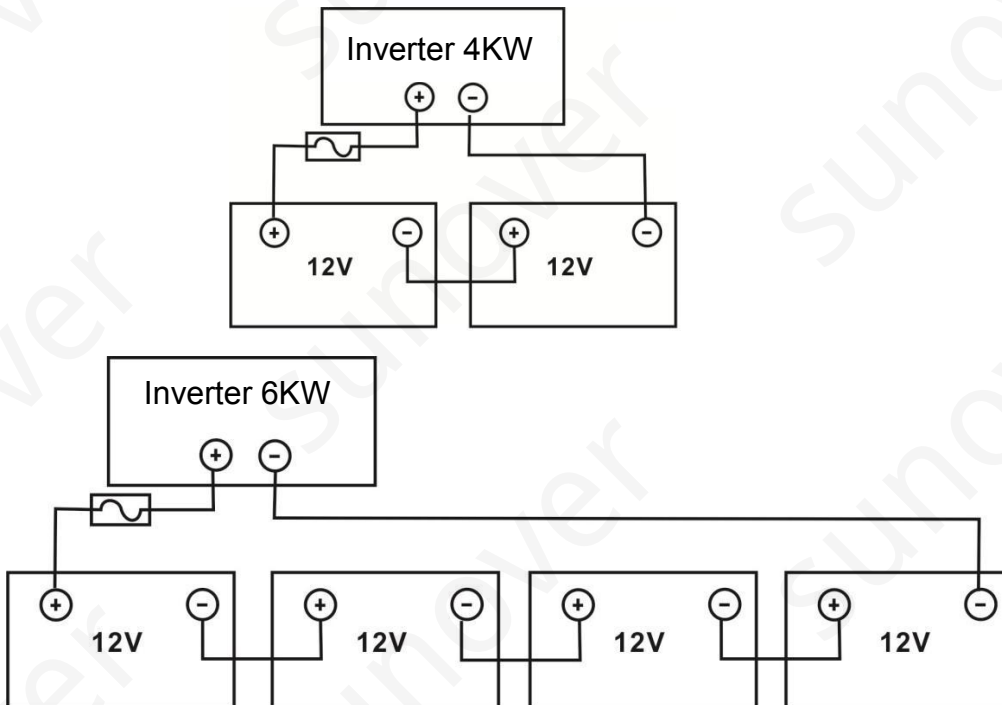

Connect the two wires to the proper screw terminal on the unit. For 4KW/6KW models, apply ring terminals to your battery wires and secure it to the battery terminal block with the bolts properly tightened. Refer to battery cable size for torque value. Make sure polarity at both the battery and the inverter is correctly connected and ring terminals are secured to the battery terminals.

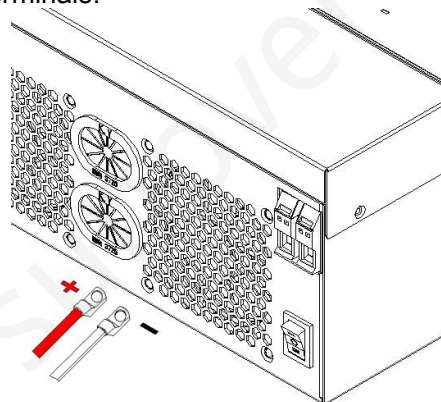

WARNING: Shock Hazard

Installation must be performed with care due to high battery voltage in series.

CAUTION!! Do not place anything between the flat part of the inverter terminal and the ring terminal.

Otherwise, overheating may occur.

CAUTION!! Do not apply anti-oxidant substance on the terminals before terminals are connected tightly.

CAUTION! Before making the final DC connection or closing DC breaker/disconnection, be sure positive (+) must be connected to positive (+) and negative (-) must be connected to negative (-).

3.5 AC Input / Output Connection

CAUTION! Before connecting to AC input power source, please install a separate AC breaker between inverter and AC input power source. This will ensure the inverter can be securely disconnected during maintenance and fully protected from over current of AC input. There commended spec of AC breaker is 32A for 4KVA and 50A for 6KVA. There are three terminal blocks with "IN" and "OUT" markings. Please do NOT connect input and output connectors wrong.

WARNING! All wiring must be performed by qualified personnel. It's very important for system safety and efficient operation to use appropriate cable for AC input connection. To reduce risk of injury, please use the proper recommended cable size as below.

Model	Gauge	Cable (mm2)	Torque Value
4KW	12AWG	4	1.2Nm
6KW	10AWG	6	1.6Nm

Please follow these steps to implement AC input/output connection:

1. Before making AC input/output connection, please disconnect the AC protector first.
2. Remove insulation sleeves for about 10mm for the five screw terminals.
3. Insert AC input wires according to polarities indicated on terminal block and tighten the terminal screws. Be sure to connect the grounding wire (⊕) first.

⊕ → Ground (yellow-green)

L → LINE (brown or black) N → Neutral (blue)

WARNING:

Be sure that the AC power source is disconnected before attempting wire connections.

This inverter is equipped with dual-output. There are four terminals (L1/N1, N2/L2 [second output]) available on output port. It's set up through LCD program "Voltage point back to AC" control the second output. Refer to "LCD setting" section for the details.

4. Insert AC output wires according to polarities indicated on terminal block and tighten terminal screws. Be sure to connect the grounding wire (⊕) first.

⊕ → Ground (yellow-green)

L → LINE (brown or black) N → Neutral (blue)

5. Make sure the wires are securely connected.

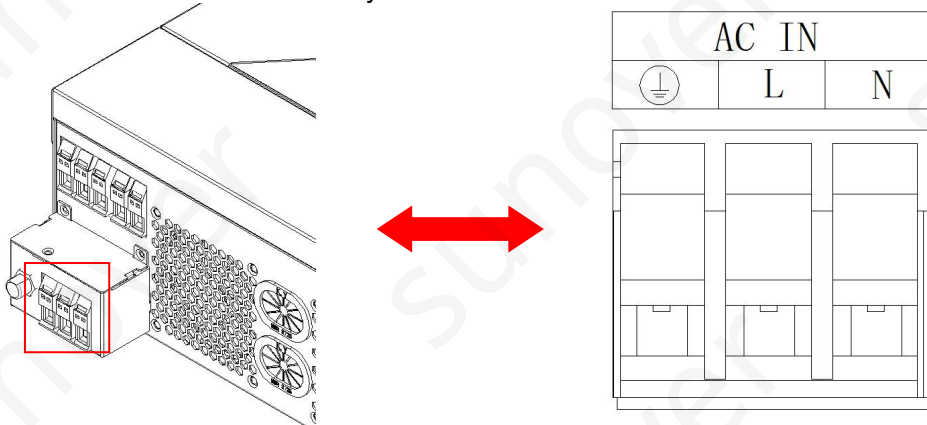

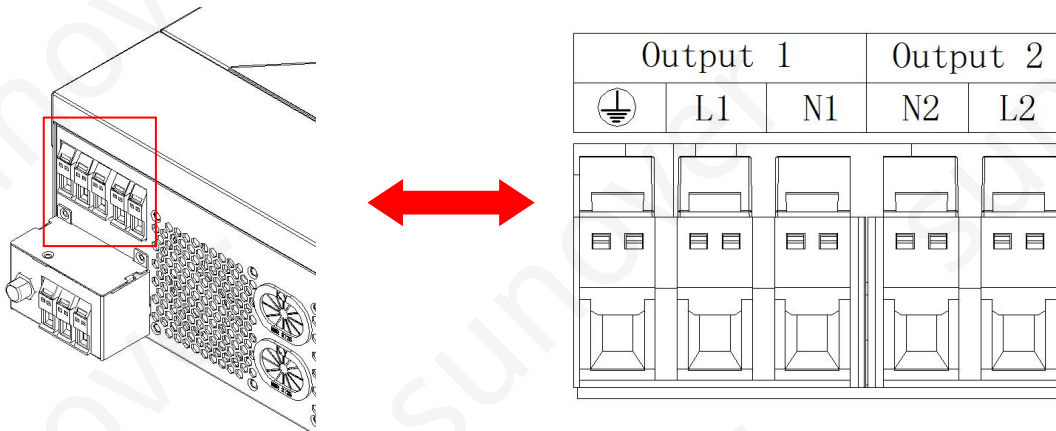

CAUTION: Appliances such as air conditioner required at least 2~3 minutes to spool up because it needs to have enough time to balance refrigerant gas inside of circuits. If a power shortage occurs and recovers in a short period of time, it may cause damage to your connected appliances. To prevent this from happening, please check with manufacturer of air conditioner if it has time-delay function before installation. Otherwise, this inverter will trigger overload fault and cut off output to protect your appliance but sometimes it may still causes damage to the air conditioner.

3.6 PV Connection

CAUTION: Before connecting to PV modules, please install a separately DC circuit breaker between the inverter and PV modules.

CAUTION: It is forbidden for inverters to share the same solar panel group.

WARNING! It's very important for system safety and efficient operation to use appropriate cable for PV module connection. To reduce risk of injury, please use the proper recommended cable size shown below.

Model	AWG Wire Size	GB Cable (mm ²)	Torque Value (max.)
4KW/6KW	1 x 12AWG	4	1.2Nm

WARNING: Because this inverter is non-isolated, are accepted: single crystalline, poly crystalline with class A-rated and CIGS modules. To avoid any malfunctions, do not connect any PV modules with possible current leakage to the inverter. For example, grounded PV modules will cause current leakage to the inverter. When using CIGS modules, please be sure NO grounding connection.

CAUTION: It's requested to use PV junction box with surge protection. Otherwise, it will cause damage on inverter when lightning occurs on PV modules.

PV Module Selection:

When selecting proper PV modules, please be sure to consider the following parameters:

1. Open circuit Voltage (Voc) of PV modules not to exceeds maximum PV array open circuit voltage of the inverter.
2. Open circuit Voltage (Voc) of PV modules should be higher than the start-up voltage.

Inverter Model	4KW	6KW
Max. PV Array Power	5000W	7000W
Max. PV Array Open Circuit Voltage	500Vdc	
PV Array MPPT Voltage Range	60Vdc~450Vdc	
Start-up Voltage	70Vdc±10Vdc	
Max. PV Input Current	27A	

Take the 250Wp PV module as an example. After considering above two parameters, the recommended module configurations are listed in the table below.

Solar Panel Spec. (reference) - 250Wp - Vmp: 30.0Vdc - Imp: 8.3A - Voc: 36.0Vdc - Isc: 8.4A	SOLAR INPUT		Q'ty of panels	Total input power
	Min. in serial: 3 pcs , max. in serial: 12 pcs			
	3 pcs in serial		3 pcs	850W
	4 pcs in serial		4 pcs	1000W
	6 pcs in serial		6 pcs	1500W
	8 pcs in serial		8 pcs	2000W
	10 pcs in serial		10 pcs	2500W
	12 pcs in serial		12 pcs	3000W
	8 pcs in serial and 2 sets in parallel		16 pcs	4000W
	9 pcs in serial and 2 sets in parallel		18 pcs	4500W
	10 pcs in serial and 2 sets in parallel		20 pcs	5000W
	11 pcs in serial and 2 sets in parallel (only for 6KVA model)		22 pcs	5500W
	12 pcs in serial and 2 sets in parallel (only for 6KVA model)		24 pcs	6000W
9 pcs in serial and 3 sets in parallel (only for 6KVA model)		27 pcs	6750W	

Take the 500Wp PV module as an example. After considering above two parameters, the recommended module configurations are listed in the table below.

Solar Panel Spec. (reference) - 500Wp - Vmp: 38.0Vdc - Imp: 13.0 A - Voc: 40.0Vdc - Isc: 14.0A	SOLAR INPUT		Q'ty of panels	Total input power
	Min. in serial: 2 pcs , max. in serial: 11 pcs			
	2 pcs in serial		2 pcs	1000W
	4 pcs in serial		4 pcs	2000W
	6 pcs in serial		6 pcs	3000W
	8 pcs in serial		8 pcs	4000W
	10 pcs in serial		10 pcs	5000W
	11 pcs in serial (only for 6KVA model)		11 pcs	5500W
	6 pcs in serial and 2 sets in parallel (only for 6KVA model)		12 pcs	6000W
	7 pcs in serial and 2 sets in parallel (only for 6KVA model)		14 pcs	7000W

PV Module Wire Connection:

Please follow below steps to implement PV module connection:

1. Remove insulation sleeve 10 mm for positive and negative conductors.
2. Suggest to put bootlace ferrules on the end of positive and negative wires with a proper crimping tool.
3. Fix PV wire cover to the inverter with supplied screws as shown in below chart.

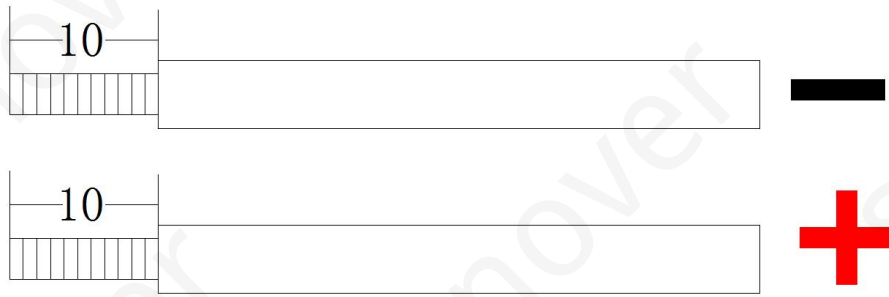

Recommended tool: M4mm blade screwdriver

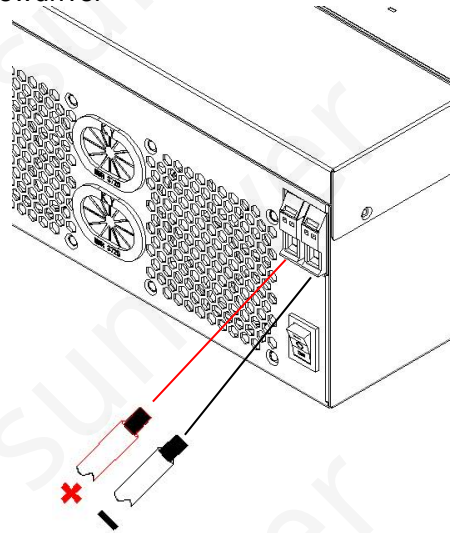

3.7 Final Assembly

After connecting all wires, please put bottom cover back by screwing screws.

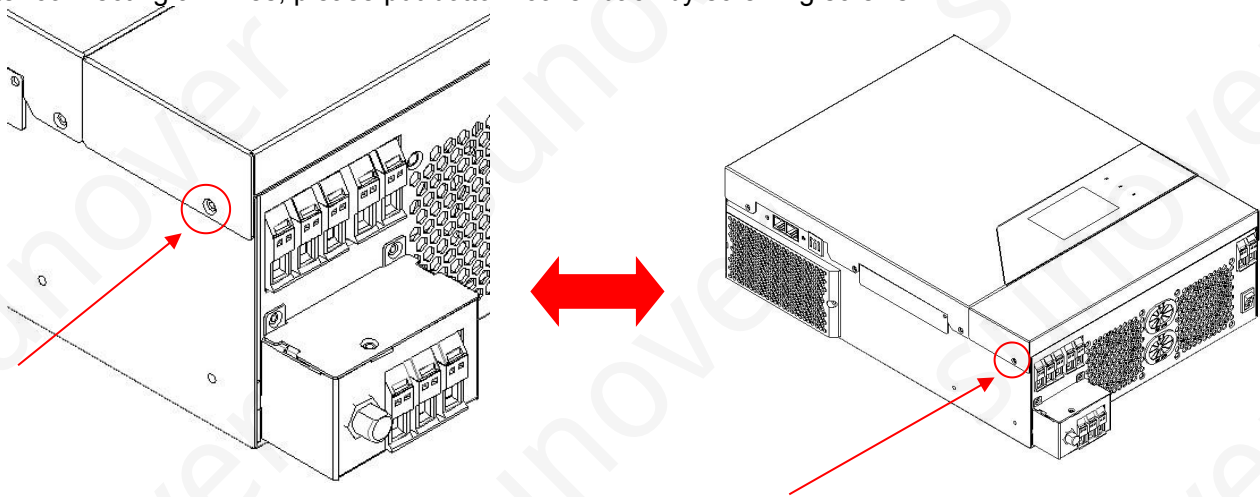

3.8 RS232 Communication Connection

Please download software “Watch power” from the official website. When the inverter is connected to the computer, the following interface will be displayed.

Note: The following dates are for reference only.

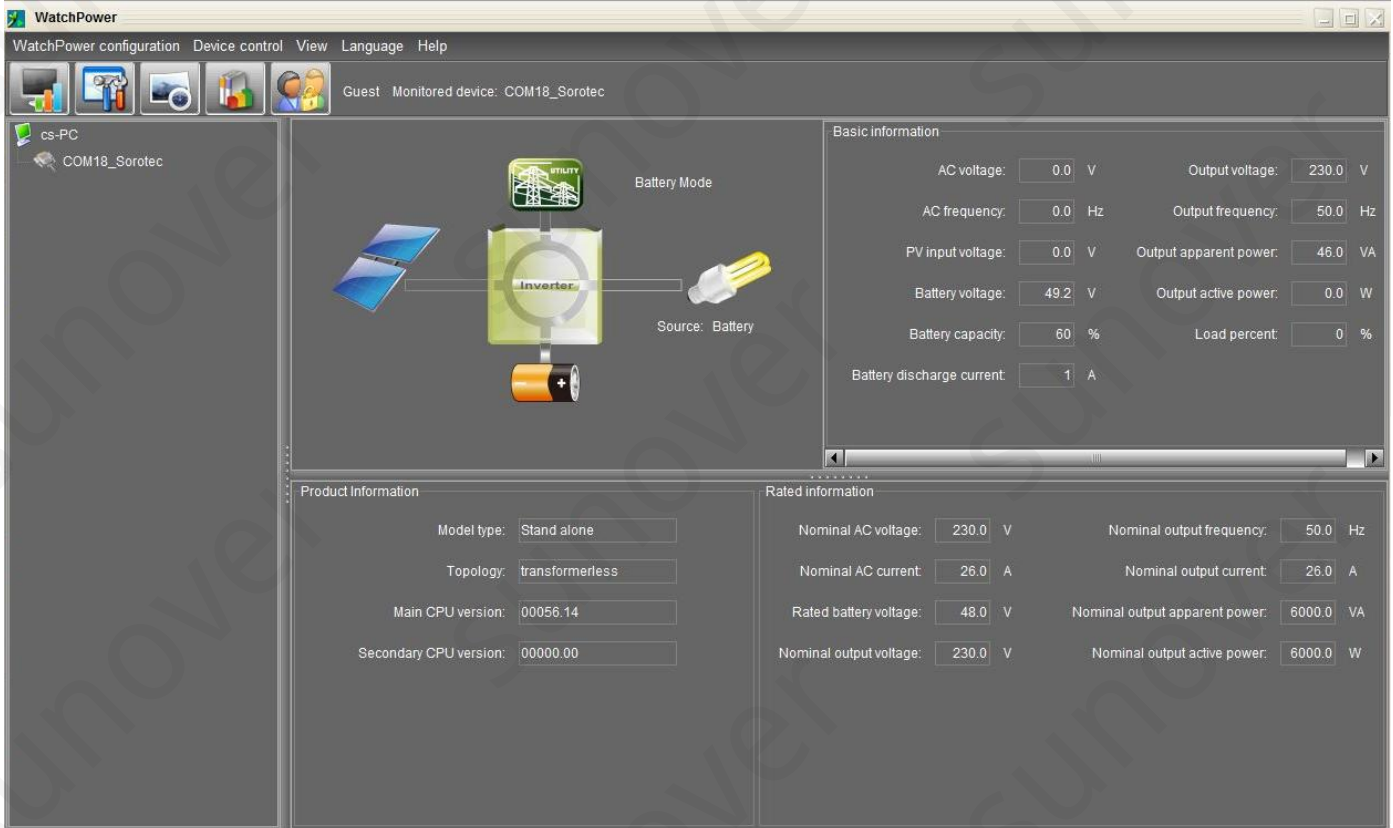

3.9 Dry Contact Signal

There is one dry contact (3A/250VAC) available on the rear panel. It could be used to deliver signal to external device when battery voltage reaches warning level.

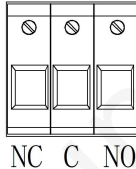
Unit Status	Condition		
		NC & C	C & NO
Power Off	Unit is off and no output is powered	Open	Close
Power On	Battery voltage <Setting the voltage in program 12	Close	Open
	Battery voltage >Setting the voltage in program 13	Open	Close

3.10 Wi-Fi Connection(Optional)

- 1.The device has its own standard WIFI port, if users need to monitor the status and information of the device through WIFI, they must connect to the WIFI collector.
- 2.Users can download “**SOLAR OF THINGS**” WIFI monitoring software from the app store on their phone.
- 3.Inverters come equipped with factory-integrated Wi-Fi capability which makes it very easy to integrate into a home network (Wi-Fi Dongle is Optional)This makes it ideal for local monitoring via the inverter's own wireless home network or for online monitoring platforms.

4. OPERATION

4.1 Power ON/OFF

Once the unit has been properly installed and the batteries are connected well, simply press On/Off switch (located on the button of the case) to turn on the unit.





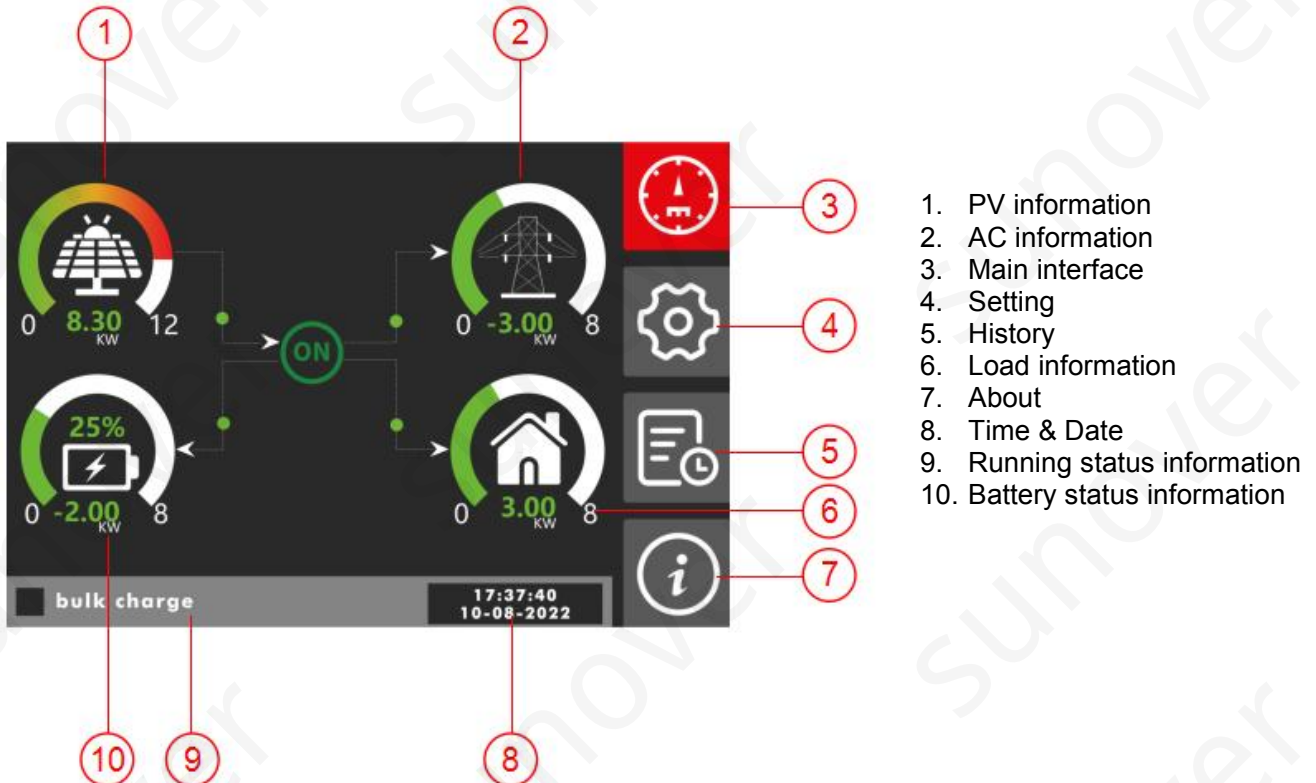



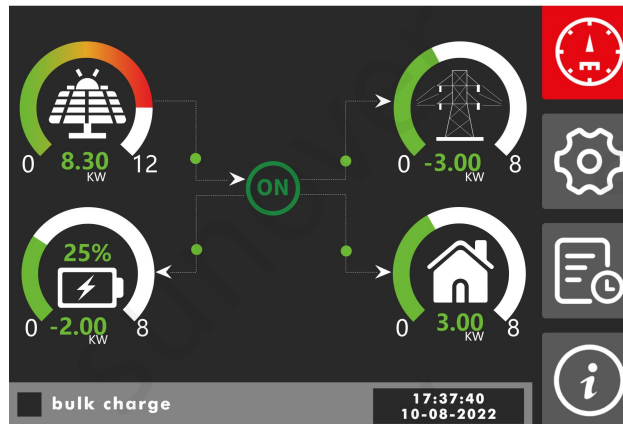

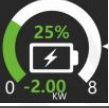
4.2 Operation and Display Panel

The operation and display panel, shown in below chart, is on the front panel of the inverter. It includes three indicators, four touchable function keys and a LCD display, indicating the operating status and input/output power information.

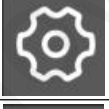

4.3 LCD Display Icons



Icons	Description
	PV voltage, current and power. Click this icon to see the PV statistics.
	Battery voltage, current and power Click this icon to see the BMS data.
	Input voltage, current and power Click this icon to see the AC statistics.
	Output voltage, current and power Click this icon to see the output statistics.
	Main interface Click this icon back to Dashboard page.
	Setting Click this icon back to Setting page.
	History Click this icon back to History page.
	About Click this icon back to About page. You can get the model and the firmware version of inverter here.
	Date & Time
	Buzzer alarm
	Inverter running status information.

4.4 LCD Setting

After click setting button, the unit will enter setting page. Setting password: 1155

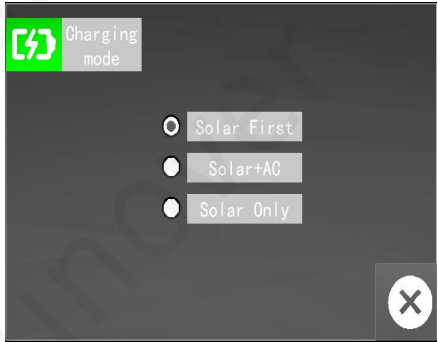
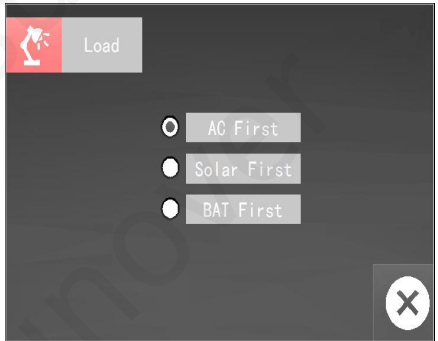
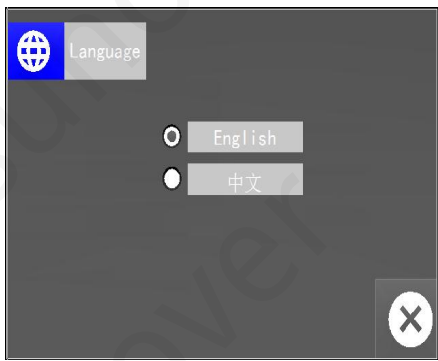
Items	Description	Select able Option	
	<p>Charger source priority: To configure charger source priority.</p>	<p>If this inverter/charger is working in Line, Standby or Fault mode, charger source can be programmed as below:</p>	
		<p>Solar first</p>	<p>Solar energy will charge battery as first priority. AC will charge battery only when solar energy is not available.</p>
		<p>Solar + AC</p>	<p>Solar energy and AC will charge battery at the same time.</p>
		<p>Solar Only</p>	<p>Solar energy will be the only charger source no matter AC is available or not.</p>
	<p>Output source priority: To configure load power source priority</p>	<p>If this inverter/charger is working in Battery mode, only solar energy can charge battery. Solar energy will charge battery if it's available and sufficient.</p>	
		<p>AC first</p>	<p>AC will provide power to the loads as first priority. Solar and battery energy will provide power to the loads only when AC power is not available.</p>
		<p>Solar first</p>	<p>Solar energy provides power to the loads as first priority. If solar energy is not sufficient to power all connected loads, battery energy will supply power the loads at the same time. Utility provides power to the loads only when any one condition happens: - Solar energy is not available - Battery voltage drops to low-level warning voltage</p>
	<p>Language</p>	<p>Battery first</p> <p>Solar energy provides power to the loads as first priority. If solar energy is not sufficient to power all connected loads, battery energy will supply power to the loads at the same time. Utility provides power to the loads only when battery voltage drops to either low-level warning voltage.</p>	
		<p>Under the language menu, customers can choose from 2 languages, including English and Chinese. Default: English Additional languages can be added according to the customer needs. To change the language, just check the corresponding language.</p>	

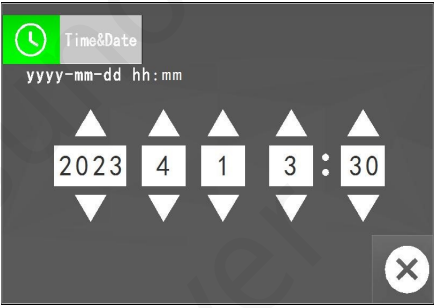
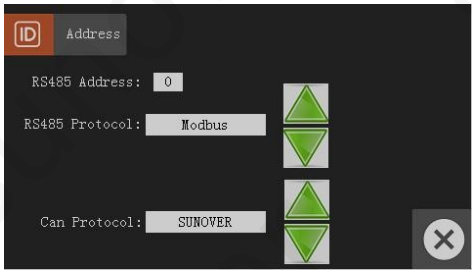
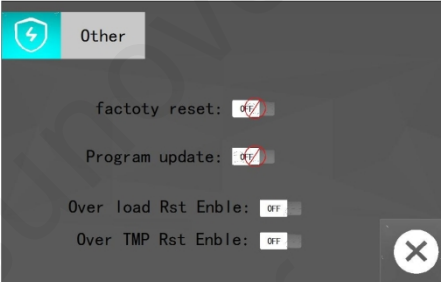
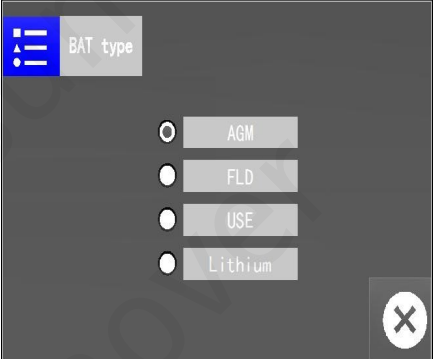
	<p>Date & Time</p>	<p>Click the button "▲" or "▼" to set the date and time. Format: yyyy-mm-dd hh:mm</p>	
	<p>Address for RS485 port and Communication Protocol</p>	<p>Set the RS485 port address of the inverter for communication with the battery. Can be set within the range of 0-999. Default:01</p> <p>Set Communication protocol options for RS485 Protocol and CAN Protocol:Modbus,SUNOVER, Pylonrch,PACE,INVT,UFO,SLP,Sorotec,Other1, Other2, Other3 RS485 Protocol: Modbus(Default) CAN Protocol: SUNOVER(Default)</p>	
	<p>Other</p>	<p>Factory reset. Program update. Setting password:1357 Over load Rst Enable. Over TMP Rst Enable. Default: OFF</p>	
	<p>Battery type</p>	<p>AGM</p>	
		<p>FLD</p>	
		<p>USE</p>	<p>User-defined, all battery parameters can be set. Default: Bulk Voltage:28.2V for 24V model :56.4V for 48V model Floating Voltage: 27.0V for 24V model : 54.0V for 48V model Cut-Off Voltage:21.0V for 24V model :42.0V for 48V model</p>
		<p>Lithium</p>	<p>Battery Discharge Limit SOC: the battery SOC is lower than such criterion, output will be shut down. Set Range of 0-80% Available when the battery type is lithium battery.</p>

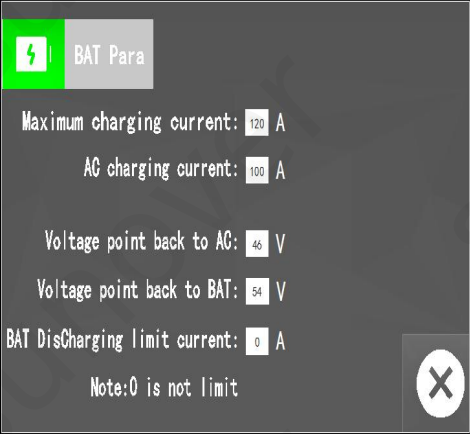
	<p>BAT Para</p>	<p>AC charging current</p>	<p>AC input 230Vac setting range:2-100A</p>
		<p>Discharging limited current:</p>	<p>If the battery discharge current is greater than the set value, the battery will stop discharging. At this point, if mains power is available, the inverter will operate in bypass mode. If there is no utility power, the inverter will turn off the output. Setting range:0-250A If the setting value is 0, the function will be disabled.</p>
		<p>Total charging current:PV+ AC</p>	<p>Total charging current, setting range: 10-120A</p>
		<p>Voltage point back to BAT</p>	<p>In the battery mode, when the battery voltage reaches the set battery voltage return point, the utility power is disconnected,and the battery inverts to supply power to the load. Set range is : 24V-29V.for 24V model 48V-58V.for 48V model</p>
		<p>Voltage point back to AC</p>	<p>In the battery mode, when the battery voltage is lower than the set mains voltage return point, the mains supplies power to the load while charging the battery to the battery voltage return point. Set range is : 22V~ 26V.for 24V model 44V~ 51V.for 48V model *Second output: When the battery voltage is lower than than the set mains voltage return point, the second output will be turned off immediately after 5 seconds. If the main is connected, the second output will be turned on immediately.</p>

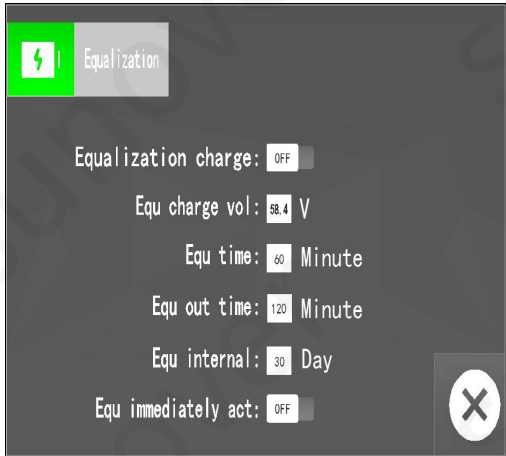
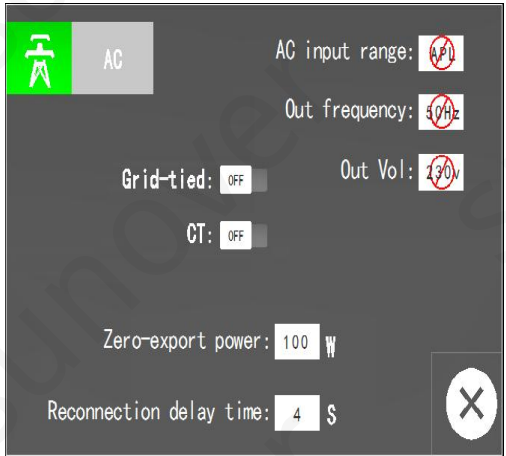
	<p>Equalization</p>	<p>Equalization charge:</p>	<p>Disable: No equalization charging Enable: Enable equalization charging, only Flooded lead-acid battery, sealed lead-acid battery and user-defined are effective</p>
<p>Charging voltage:</p>		<p>Equalization Charging Voltage, with the set range of 25V-30V for 24V model and 48V-60V for 48V model available for Flooded lead-acid battery, sealed lead-acid battery and user-defined.</p>	
<p>Charging time:</p>		<p>Equalization Charging Time, with the Set Range of 5min-900min, available for Flooded lead-acid battery, sealed lead-acid battery and user-defined.</p>	
<p>Charging delay:</p>		<p>Equalization Charging Delay, with the set range of 5min-900min, available for Flooded lead-acid battery, sealed lead-acid battery and user-defined.</p>	
<p>Charging Interval Time:</p>		<p>Equalization Charging Delay, with the set range of 0-90D, available for Flooded lead-acid battery, sealed lead-acid battery and user-defined.</p>	
<p>Forced equalization:</p>		<p>Start equalization charging immediately.</p>	
		<p>AC input</p>	<p>AC input range</p>
<p>Out frequency</p>	<p>50Hz/60Hz</p>		
<p>Out Voltage</p>	<p>220V/230V/240V</p>		
<p>CT</p>	<p>OFF/ON</p>		
<p>Zero Export power</p>	<p>Range:0-999W</p>		
<p>Re connection delay time:</p>	<p>When the utility is connected, the waiting time can be set. After reaching the waiting time, the utility will start working. Range:0-999S</p>		
<p>Grid-tied</p>	<p>When the system supply mode is AC first and the battery is full or not-connected, the system with sufficient solar energy will work in grid connected power generation mode.</p>		

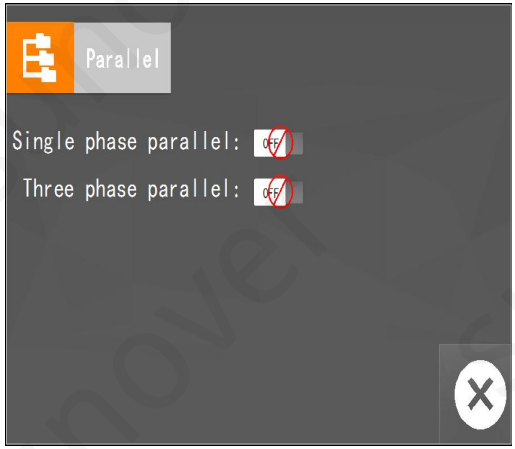
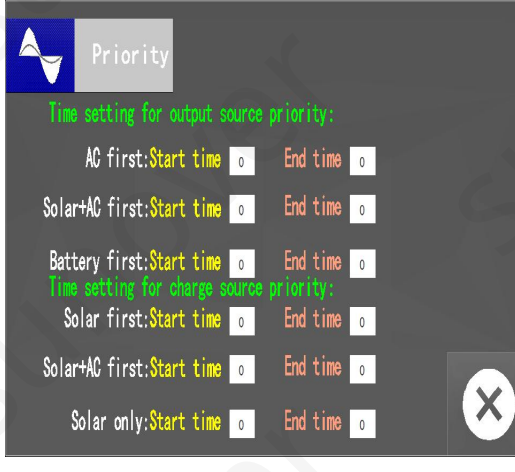
	<p>Parallel setting</p>	<p>Single phase</p>	<p>Single phase parallel</p>
<p>Three phases</p>		<p>The phase needs to be set to one of A, B, and C.</p>	
<p>Disable</p>		<p>Parallel function is disabled. This setting is only available when the inverter is in standby mode (Switch off).</p>	
	<p>Peak Valley</p>	<p>Timer 1</p>	<p>Timer start time. Type: discharge or charge</p>
<p>Timer 2</p>		<p>Timer start time. Type: discharge or charge</p>	
<p>Timer 3</p>		<p>Timer start time. Type: discharge or charge</p>	
<p>Timer 4</p>		<p>Timer start time. Type: discharge or charge</p>	

4.5 Parallel function operation instructions (Optional)

(Maximum of 6 parallel units)

CAUTION: It is forbidden for inverter to share the same solar panel group.

Single phase parallel:

1. Connecting the parallel communication line and power cable as shown below

Warning: All inverters must share the same battery pack when paralleling.

2. Set the parameters of each inverter separately (working mode, single-phase parallel function).

Warning: When working in parallel, the working mode of each inverter must be the same working mode.

3. After setting the parameters, turn on each inverter in turn.

Two inverters parallel:

Power Connection:

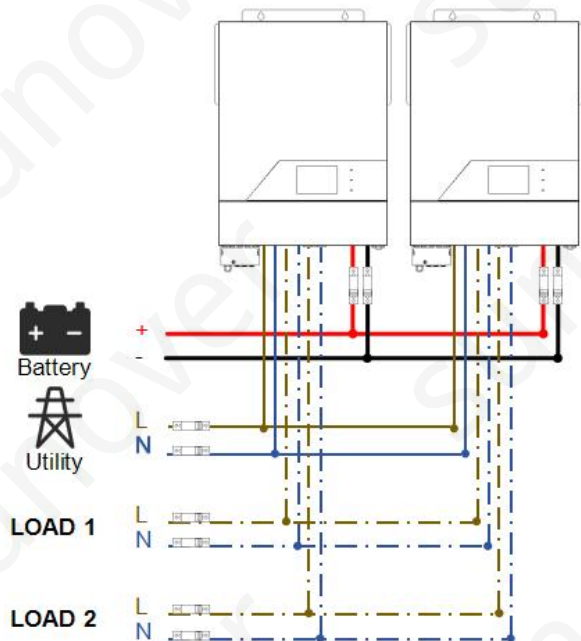

Communication Connection:

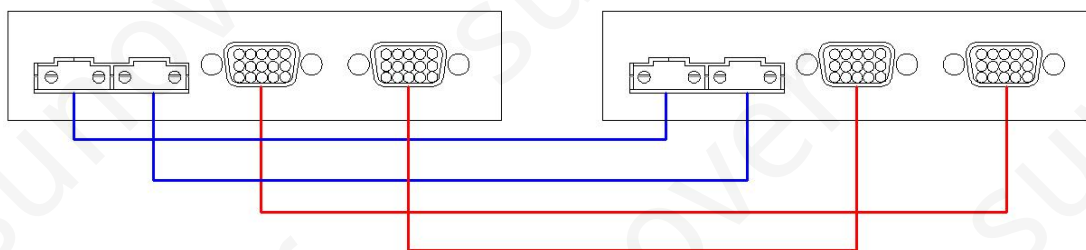

Three inverters parallel:
Power Connection:

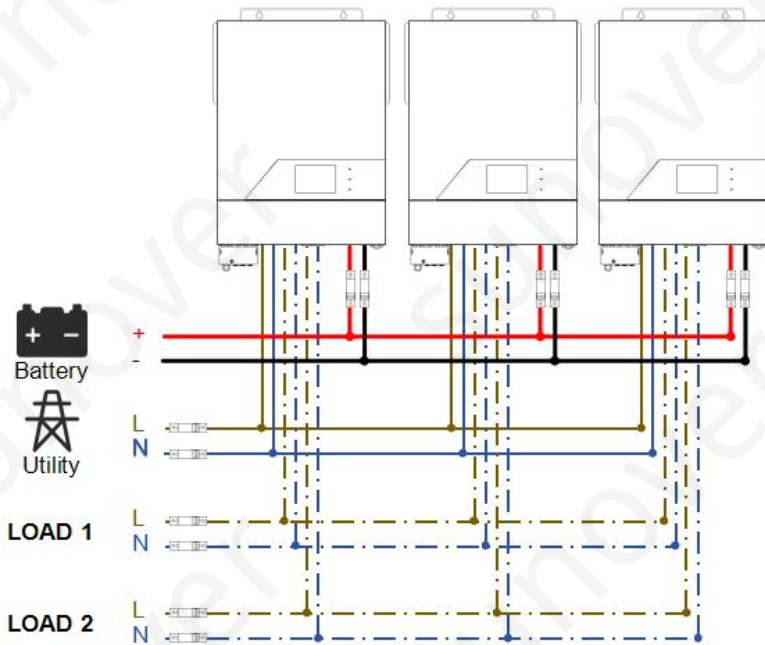

Communication Connection:

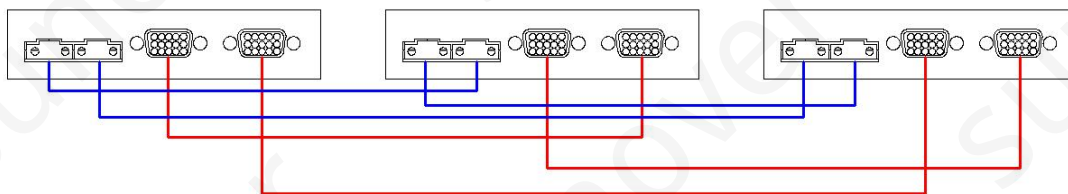

Four inverters parallel:
Power Connection:

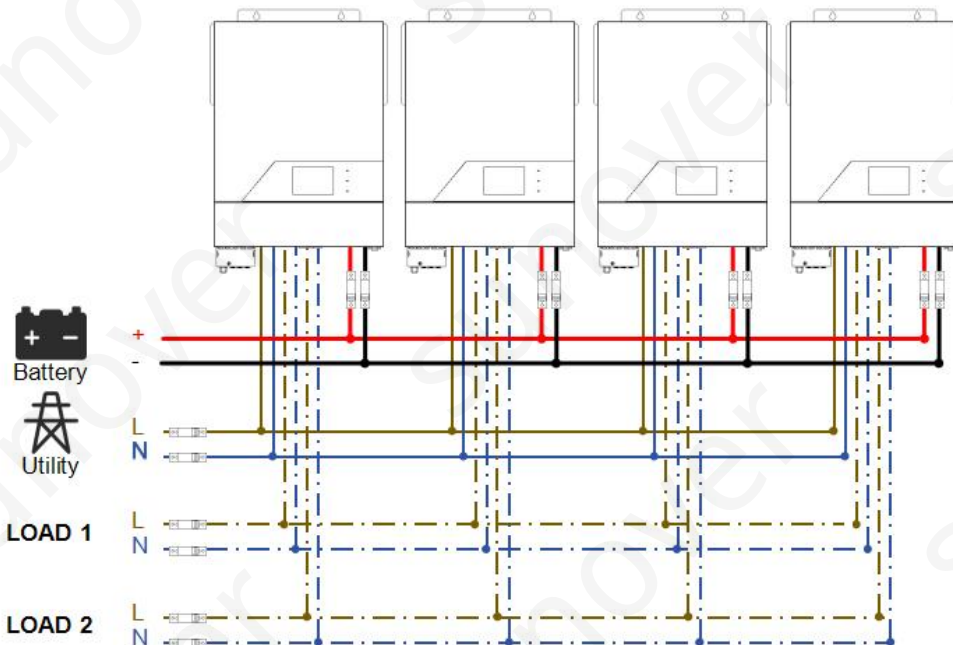

Communication Connection:

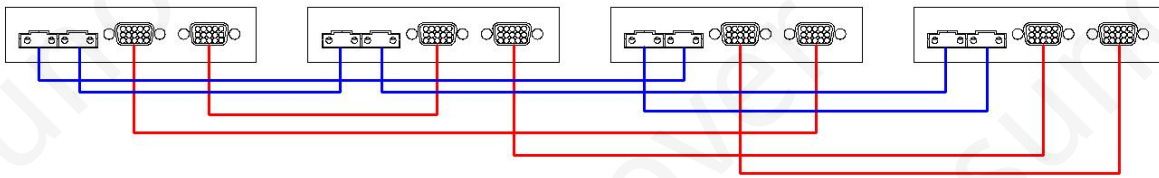

Five inverters parallel:
Power Connection:

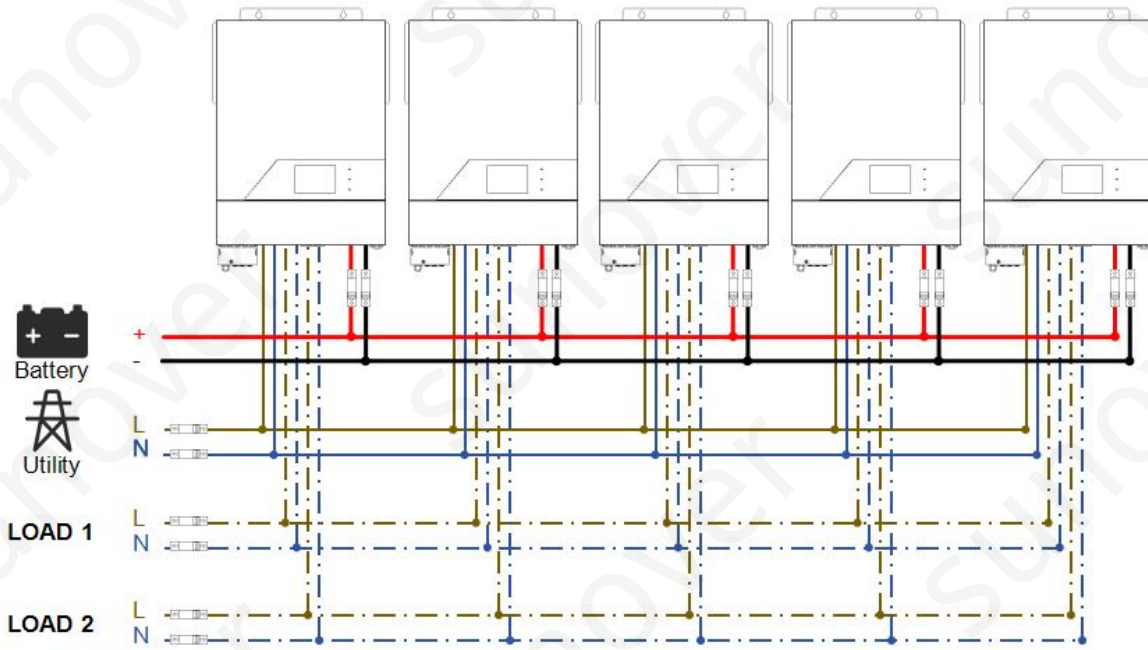

Communication Connection:

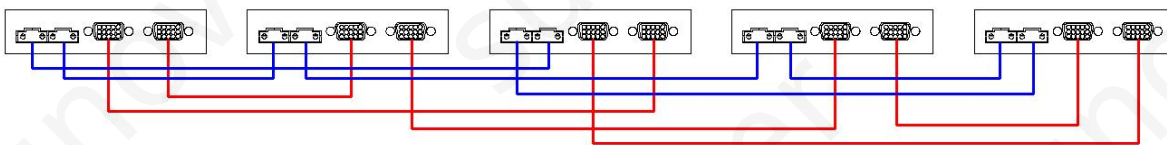

Six inverters parallel:
Power Connection:

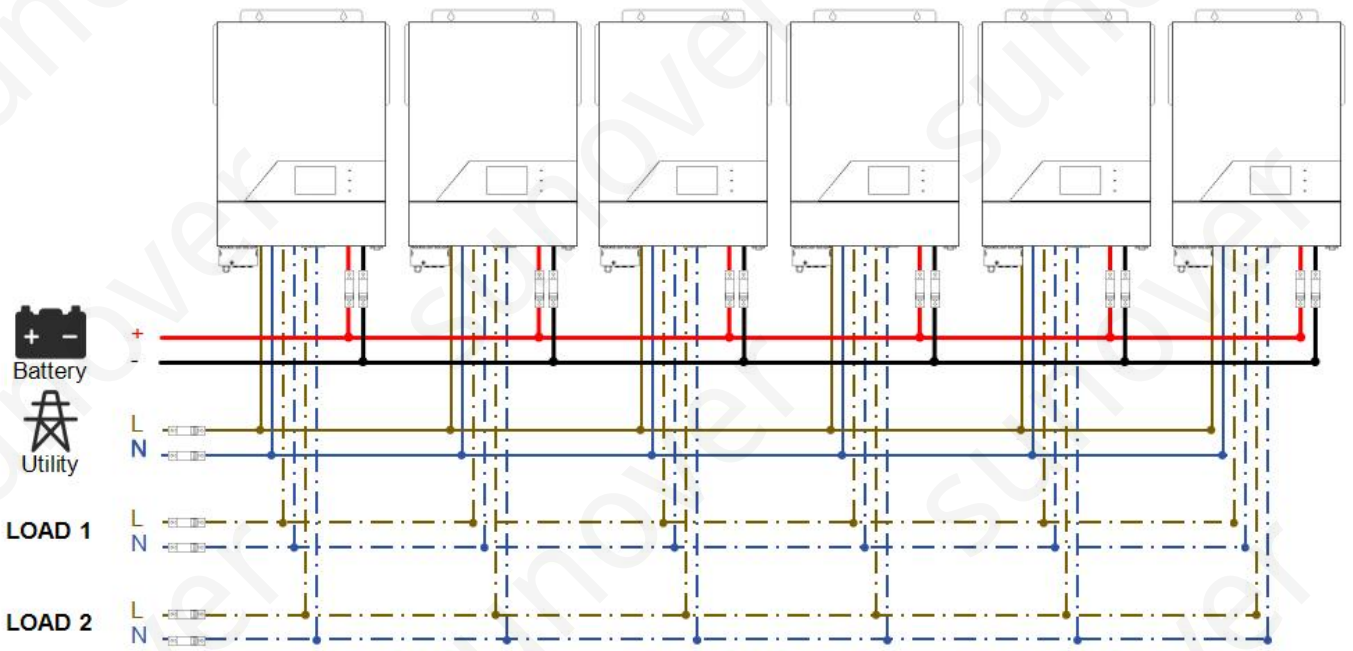

Communication Connection:

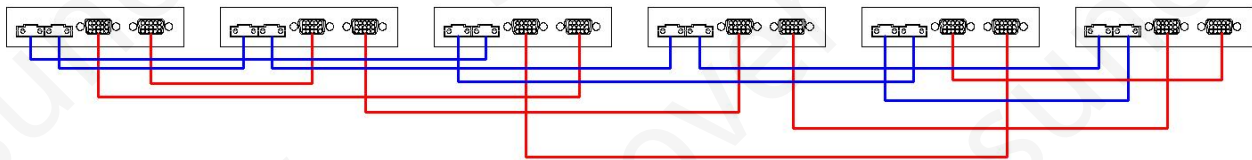

Three-phase parallel:

CAUTION: It is forbidden for inverter to share the same solar panel group.

1. Connecting the parallel communication cables and power cables as shown below:

Warning: All inverters must share the same battery pack when paralleling

2. Set the parameters of each inverter independently (working mode, single-phase parallel function, three-phase parallel function and set A/B/C phase sequence).

Warning: When working in parallel, the working mode of each inverter must be the same.

3. After setting the parameters, first turn on the A phase inverter and then turn on each inverters in turn.

One inverters in each phase:

Power connection:

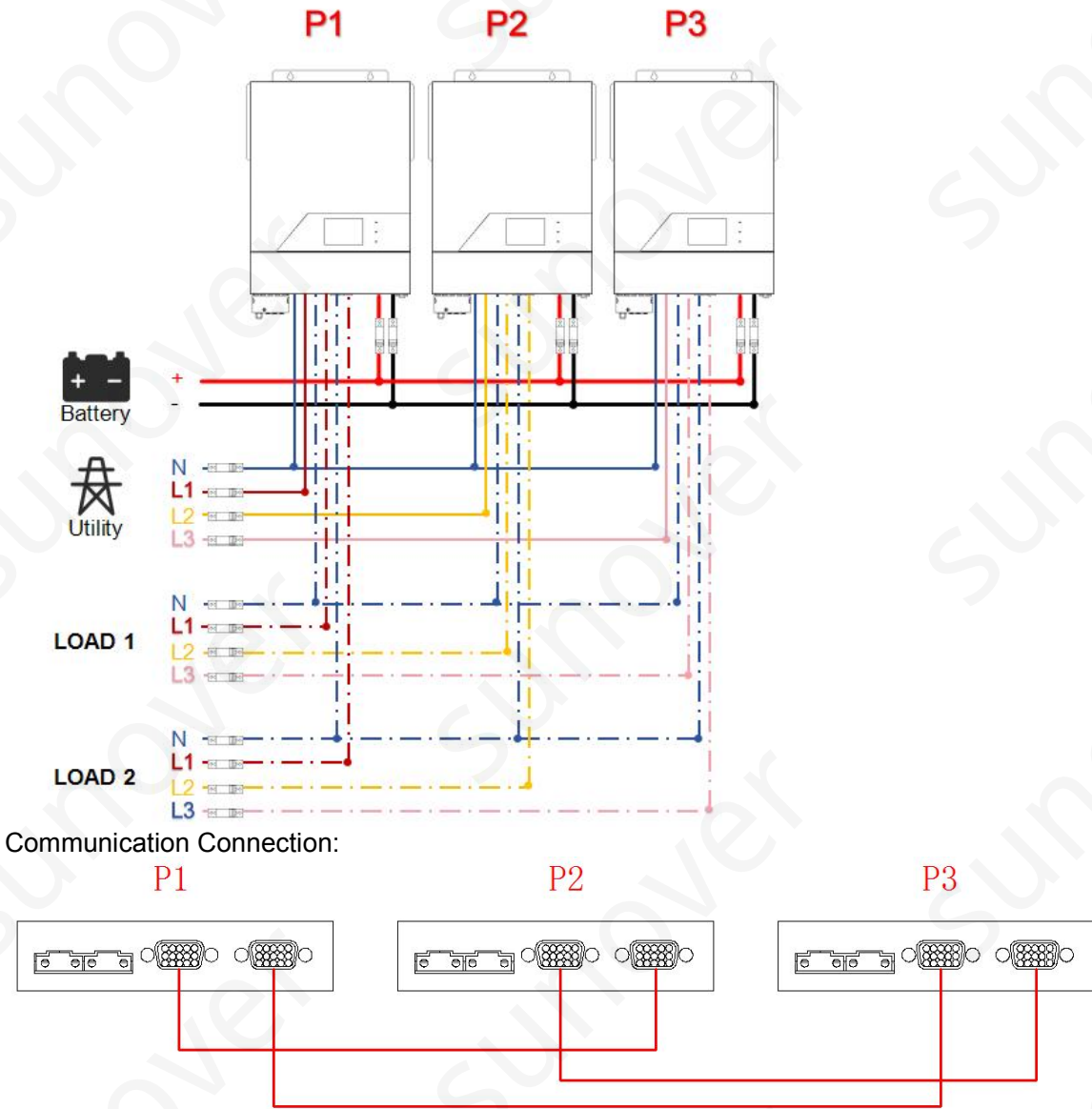

Two inverters in each phase:
Power connection:

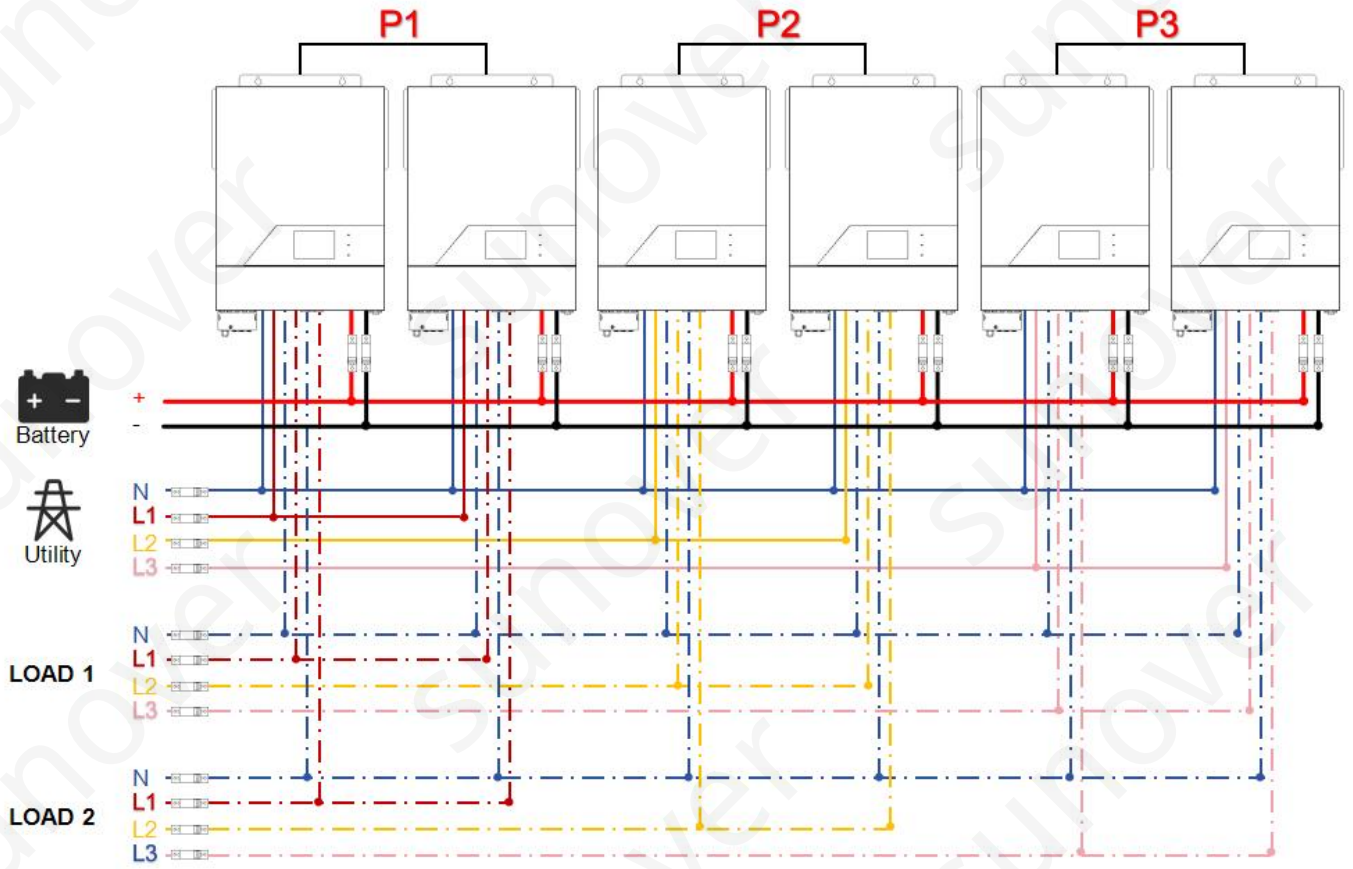

Communication Connection:

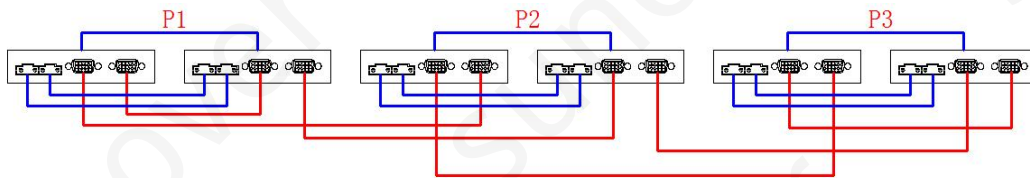

Three inverters in one phase and only one inverter for the remaining two phases:
Power Connection:

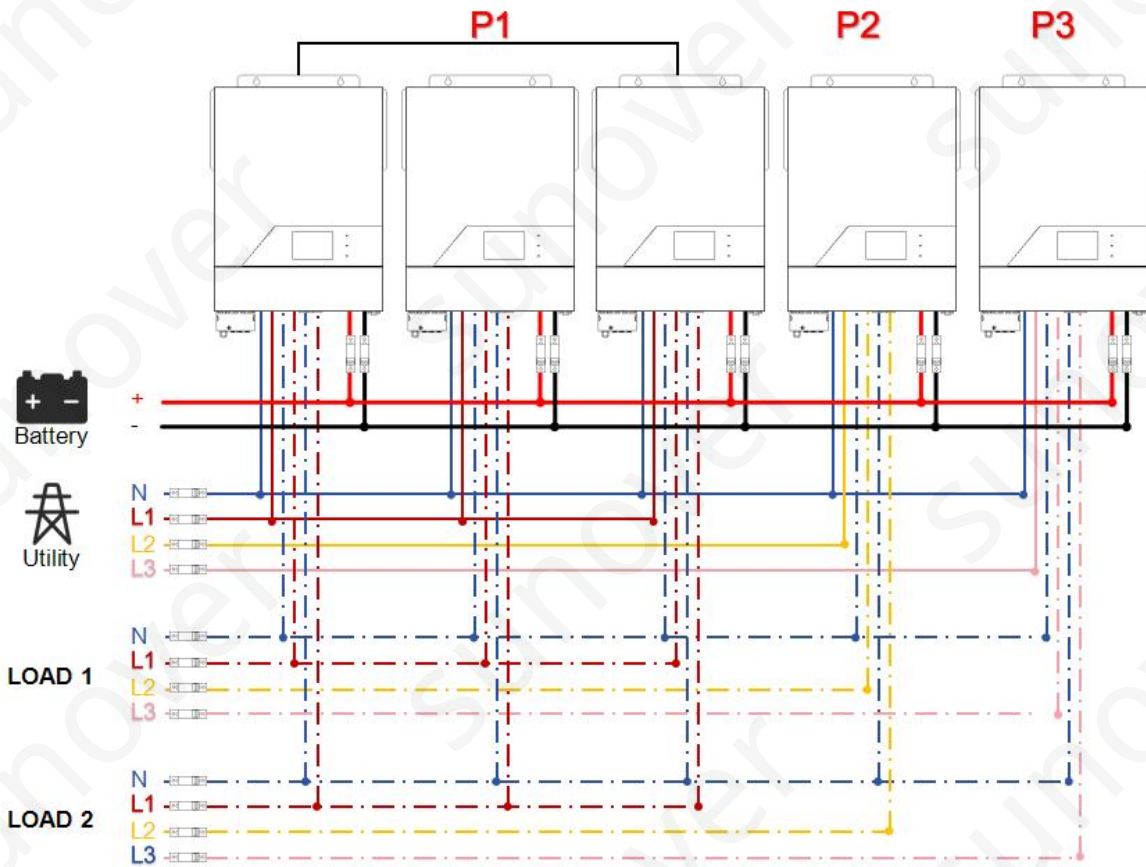

Communication Connection

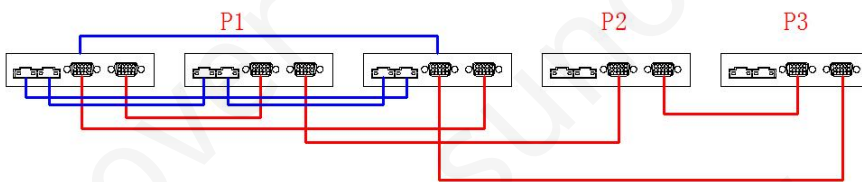

Three inverters in one phase, two inverters in second phase and one inverter for the third phase:
 Power Connection:

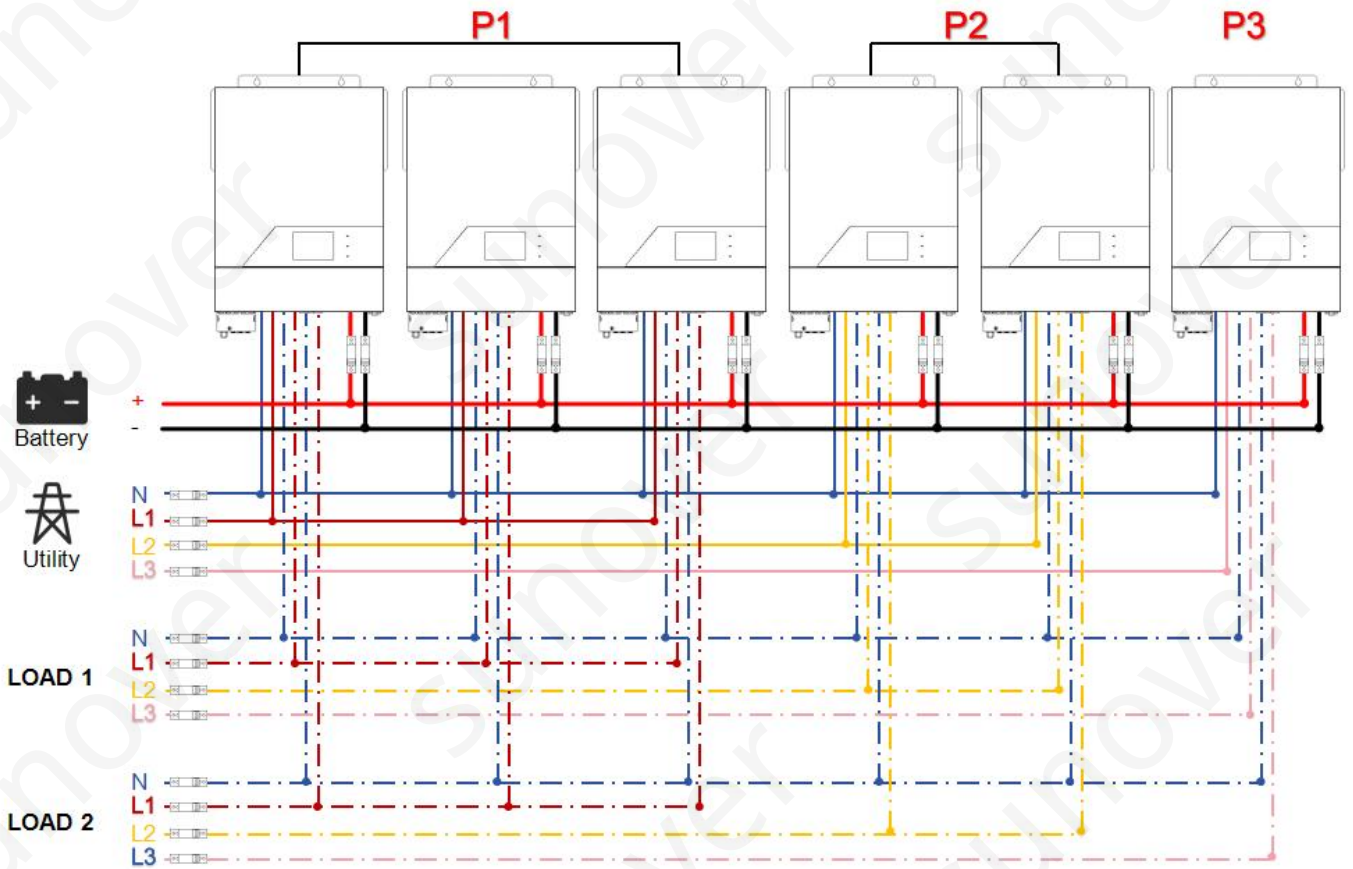

Communication Connection

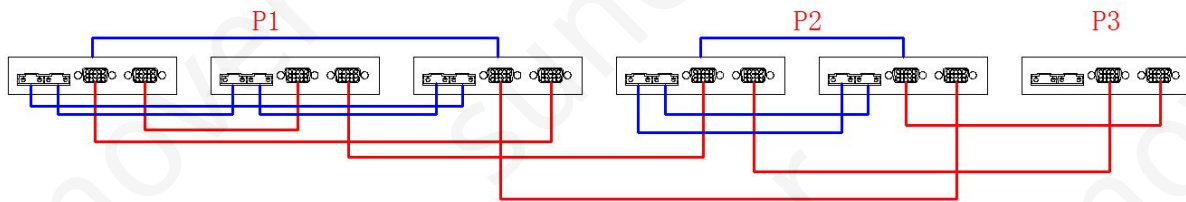

Four inverters in one phase and one inverter for the other two phases:
Power Connection:

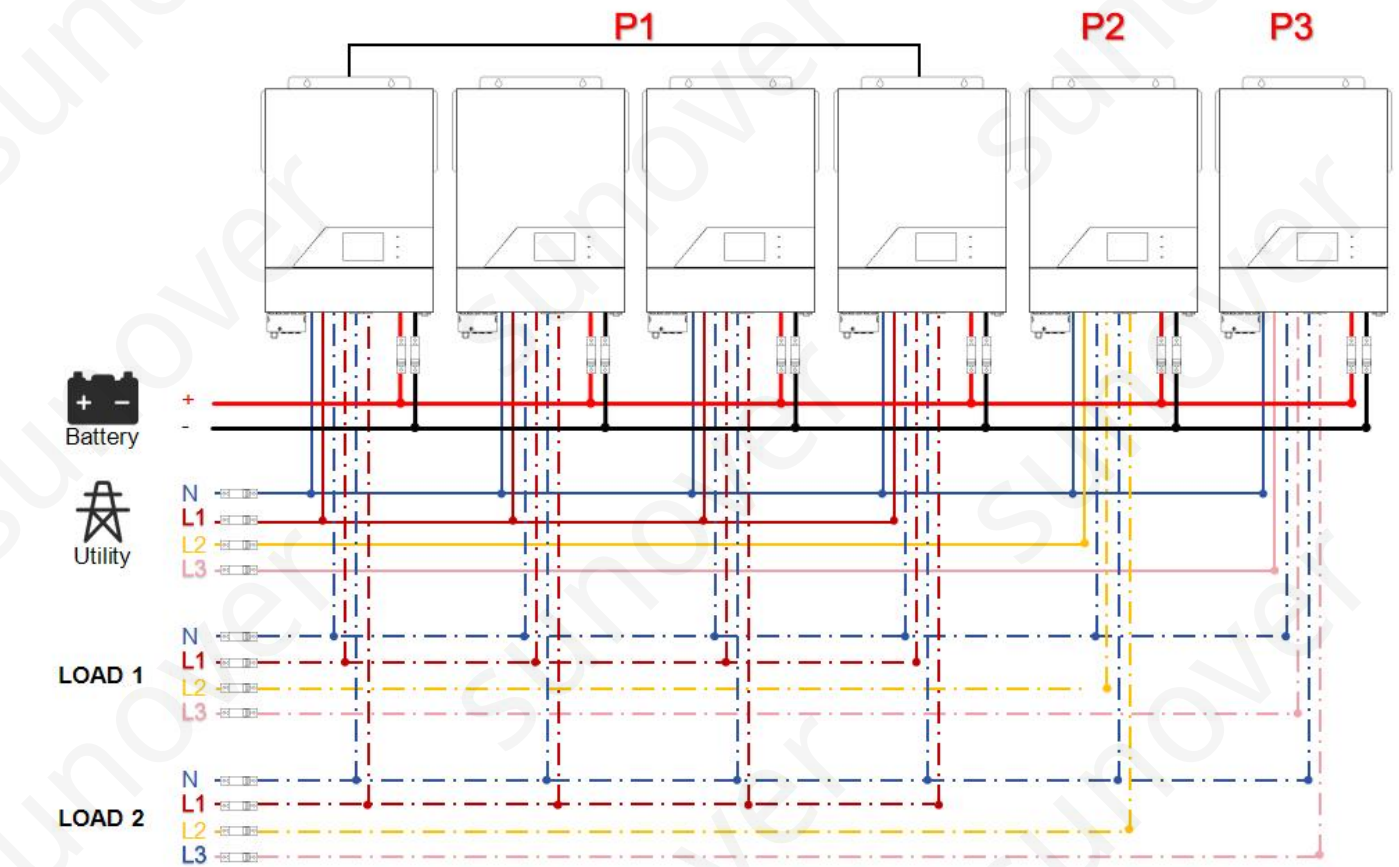

Communication Connection

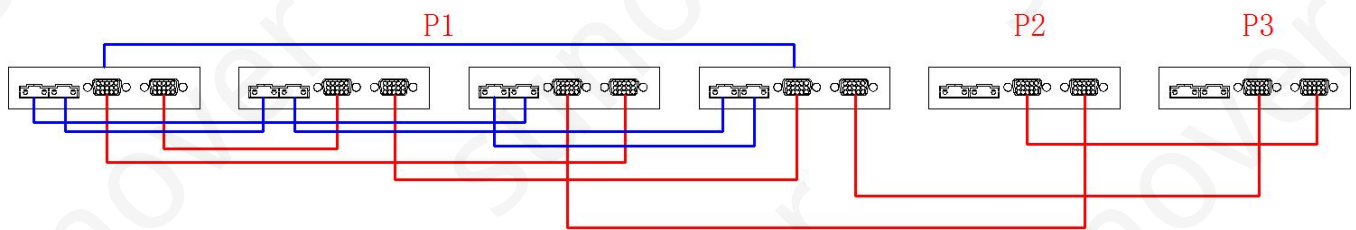

Two inverters in two phases and only one inverter for the remaining phase:
Power Connection:

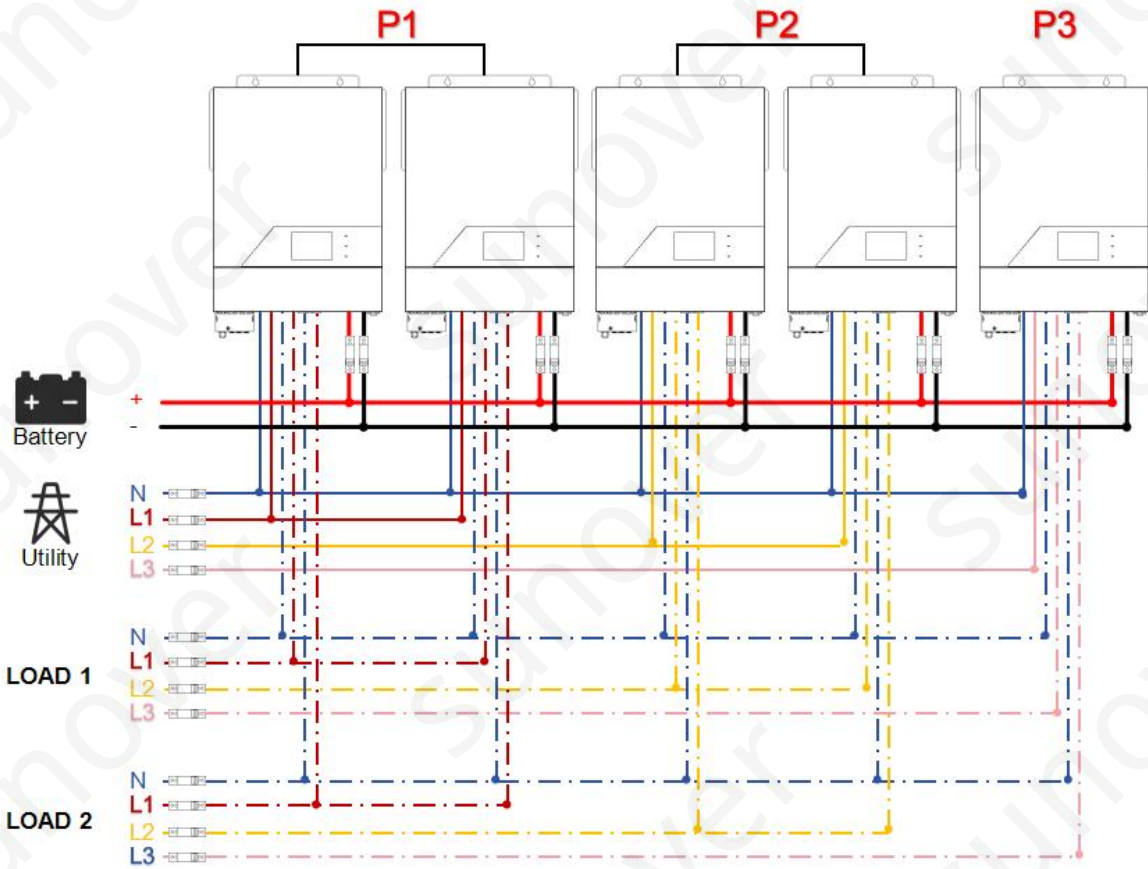

Communication Connection

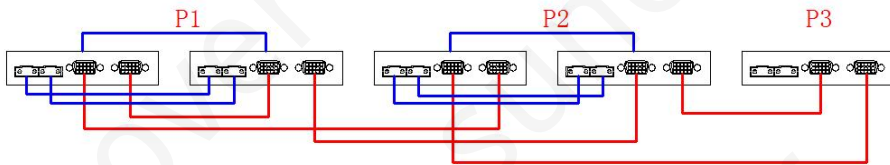

Two inverters in one phase and only one inverter for the remaining phases:
Power Connection:

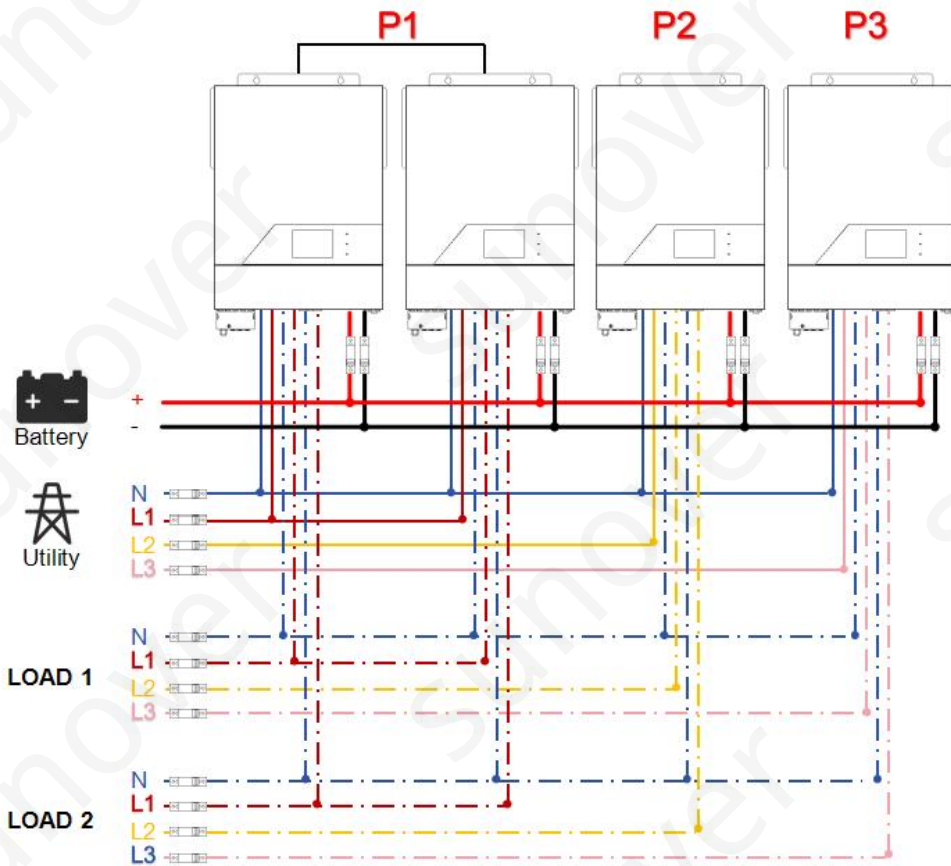

Communication Connection

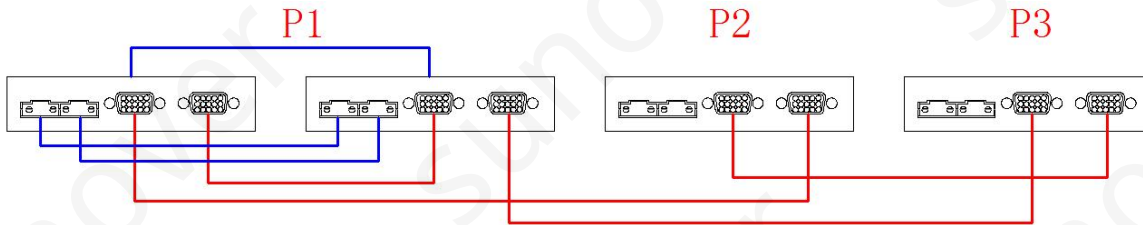

4.6 Battery Equalization Description

Battery equalization function is built into the charge controller. It reverses the buildup of negative chemical effects such as stratification, a condition where acid concentration is greater at the bottom of the battery than at the top. Equalization also helps to remove sulfate crystals that may have built up on the plates. If left unchecked, this condition, called sulfating, will reduce the overall capacity of the battery. Therefore, it's recommended to equalize the battery periodically.

How to Activate Equalization Function

You must enable battery equalization function in LCD setting Program 30 first. Then you can apply this function by either one of the following methods.

1. Setting equalization interval in Program 35.
2. Activate equalization immediately in Program 36.

When to Equalize

In floating charge stage, when setting the equalization interval (battery equalization cycle) is reached, or equalization is activated immediately, the controller will start to enter Equalize Mode.

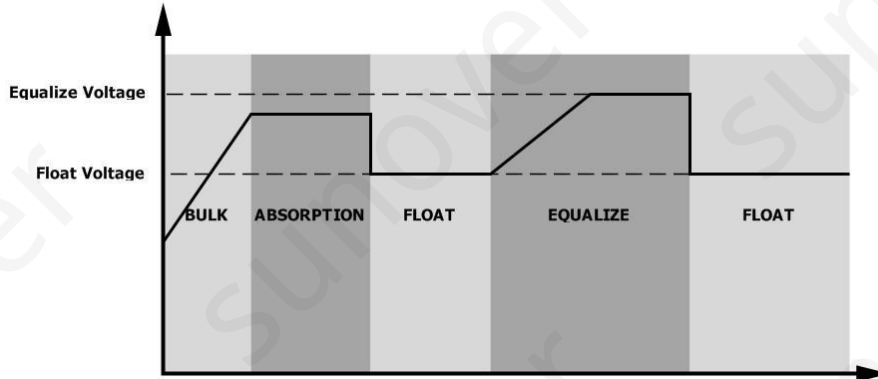

Equalize Charging and Timeout

In Equalize Mode, the controller will supply power to charge battery as much as possible until battery voltage reach the equalization voltage. Then, constant-voltage regulation is applied to maintain battery voltage at the equalization level. The battery will remain in the Equalize Mode until the equalization timer runs out.

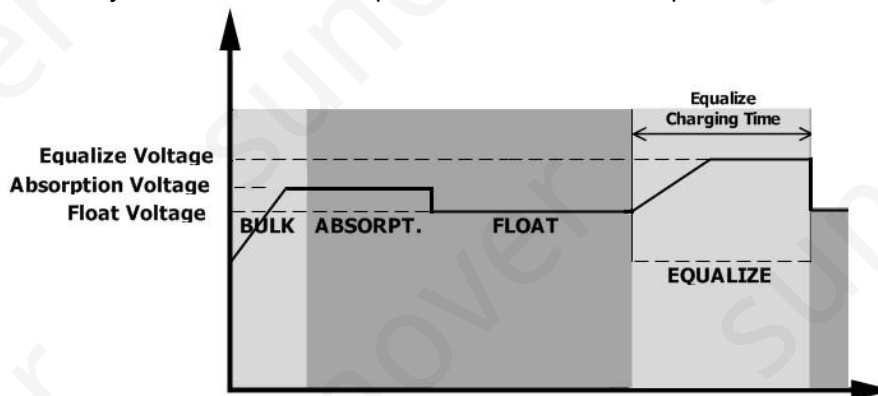

However, in Equalize Mode, if the battery equalization timer runs out and the battery voltage doesn't recover to the battery equalization voltage point, the charge controller will extend the battery equalized time until battery voltage to equalization voltage. If the battery voltage is still lower than equalization voltage when the extension runs out, the charge controller will stop equalization and return to the floating charging stage.

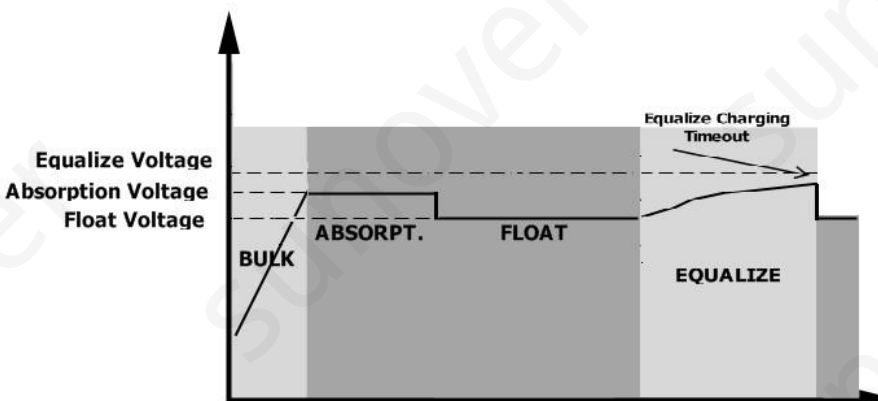

4.7 Fault Reference Code

Fault Code	Fault Event
01	Fan is locked when inverter is off
02	Over temperature
03	Battery voltage is too high
04	Battery voltage is too low
05	Output short circuited or over temperature is detected by internal converter components
06	Output voltage is too high
07	Overload time out
08	Bus voltage is too high
09	Bus soft start failed
51	Over current or surge
52	Bus voltage is too low
53	Inverter soft start failed
55	Over DC voltage in AC output
57	Current sensor failed
58	Output voltage is too low
59	PV voltage is over limitation

4.8 Warning Indicator

Warning Code	Warning Event
01	Fan is locked when inverter is on.
02	Over temperature
03	Battery is over-charged
04	Low battery
07	Overload
10	Output power derating
15	PV energy is low.
16	High AC input (>280VAC) during BUS soft start
E9	Battery equalization
bP	Battery is not connected

4.9 Parallel Faults Code

Fault Code	Fault Event
60	Power feedback protection
71	Firmware version inconsistent
72	Current sharing fault
73	Output voltage different
80	CAN fault
81	Host loss
82	Synchronization loss
83	Battery voltage detected different
84	AC input voltage and frequency detected different
85	AC output current unbalance
86	AC output mode setting is different

5. TROUBLE SHOOTING

Problem	LCD/LED/Buzzer	Possible cause	What to do
Unit shuts down automatically during start up process	LCD/LED and buzzer will be active then complete off	The battery voltage is too low	1.Re-charge battery. 2.Replace battery
No response after power on	No indication	1.The battery voltage is too low. 2.Internal fuse tripped	1.Contact repair center for replacing the fuse. 2.Re-charge battery. 3.Replace battery.
Mains exist but the unit works in battery mode	Input voltage is displayed as '0' on the LCD and green LED is flashing	Input protector is triggered	Check if AC breaker is turned on and AC wiring is connected well.
	LED is flashing	Insufficient quality of AC power(grid or generator)	1.Check if AC wires are too thin and/or too long. 2.Check if generator (if applied) is working well or if input voltage range setting is correct.
When the unit is turned on, internal relay is switched on and off repeatedly	LCD display and LED flashing	Set "Solar First" as the priority of output source.	Change output source priority to utility first.
Buzzer beeps continuously and red LED is on	Fault code 01	Fan fault	Replace the fan
	Fault code 02	Internal temperature of inverter component is over 85°C	Check whether the environment around the equipment well ventilated
	Fault code 03	The battery voltage is too high	Check if spec and quantity of batteries are meet requirements
		battery is over charged	Return to repair center
	Fault code 04	The battery voltage is too low	1.The battery is dead, please charge the battery immediately 2.Check the battery for damage
	Fault code 05	Output short circuited	1.Check that the output cable is connected 2.Return to the maintenance center
	Fault code 06/58	Output abnormal (Inverter voltage range 180-260VAC)	Return to the maintenance center
	Fault code 07	Overload error , the inverter is overload 110% and overload time reaches the upper limit	Reduce load

Buzzer beeps continuously and red LED is on	Fault code 08/09/12/53/57	Internal fault of inverter	Return to the maintenance center
	Fault code 10	Over current or surge	Remove abnormal load or check PV input
	Fault code 11	The configuration of the solar panel is higher than the PV input voltage required by the inverter	Remove the excess solar panels
	Fault code 13	Battery discharge over current	Please check whether the discharge current of Item 40 is lower than the discharge current of the inverter
	Fault code 52/55	Internal fault of inverter	Return to the maintenance center
	Fault code 60	Power feedback protection	<ol style="list-style-type: none"> 1.Restart the inverter. 2.Check if L/N cables are not connected reversely in all inverters. 3.For parallel system in single phase ,make sure the sharing are connected in all inverters. for supporting three-phase system, make sure the sharing cables are connected in the inverters in the same phase. and disconnected in the inverters in different phase.
	Fault code 71	Firmware version inconsistent	<ol style="list-style-type: none"> 1.Update all inverter firmware to the same version 2.If the problem remains ,please contact your installer.
	Fault code 72	The output current of each inverter is different	<ol style="list-style-type: none"> 1.check if sharing cables are connected well and restart the inverter. 2.if the problem remains ,please contact your installer.
	Fault code 73	AC output voltage setting is different	Check whether the output voltage of each inverter are set the same

Buzzer beeps continuously and red LED is on	Fault code 80	CAN data loss	1. Check if communication cables are connected well and restart the inverter 2. If the problem remains, please contact your installer.
	Fault code 81	Host data loss (only for three-phase parallel)	
	Fault code 82	Synchronization data loss	
	Fault code 83	The battery voltage of each inverter is not the same.	1. Make sure all inverters share same groups of batteries together. 2. Remove all loads and disconnect AC input and PV input. Then, check battery voltage of all inverters. If the values from all inverters are close, please check if all battery cables are the same length and same material type. Otherwise, please contact your installer to provide SOP to calibrate battery voltage of each inverter. 3. If the problem still remains, please contact your installer.
	Fault code 84	AC input voltage and frequency detected different	Check whether the input voltage and frequency of each inverter are set the same
	Fault code 85	AC output current unbalance	1. Restart the inverter 2. Remove some excessive loads and re-check load information from LCD of inverters. If the values are different, please check if AC input and output cables are in the same length and material type.
	Fault code 86	AC output mode setting is different.	1. Check whether it is set to parallel mode 2. Return to the maintenance center

6. SPECIFICATIONS

Table 1 Line Mode Specifications

INVERTER MODEL	4KW	6KW
Input Voltage Waveform	Sinusoidal (utility or generator)	
Nominal Input Voltage	230Vac	
Low Loss Voltage	170Vac±7V (narrow range); 90Vac±7V (wide range)	
Low Loss Return Voltage	180Vac±7V (narrow range); 100Vac±7V (wide range)	
High Loss Voltage	280Vac±7V	
High Loss Return Voltage	270Vac±7V	
Max AC Input Voltage	300Vac	
Nominal Input Frequency	50Hz / 60Hz (Auto detection)	
Low Loss Frequency	40±1Hz	
Low Loss Return Frequency	42±1Hz	
High Loss Frequency	65±1Hz	
High Loss Return Frequency	63±1Hz	
Output Short Circuit Protection	Circuit Breaker	
Efficiency (Line Mode)	>95% (Rated R load, battery full charged)	
Transfer Time	10ms typical (wide range); 20ms typical (narrow range)	
Output power derating: When AC input voltage drops to 170V, the output power will be derated.	<p>The graph plots Output Power on the vertical axis against Input Voltage on the horizontal axis. The horizontal axis has markers at 90V, 170V, and 280V. The vertical axis has markers for 50% Power and Rated Power. The power is zero for input voltages below 90V. At 90V, the power jumps to 50% of the rated power. From 90V to 170V, the power increases linearly to reach the Rated Power level. From 170V to 280V, the power remains constant at the Rated Power level. Above 280V, the power drops to zero.</p>	

Table 2 Inverter Mode Specifications

INVERTER MODEL	4KW	6KW
Rated Output Power	4000W	6000W
Output Voltage Waveform	Pure Sine Wave	
Output Voltage Regulation	230Vac±5%	
Output Frequency	50Hz	
Peak Efficiency	93%	
Overload Protection	5s@≥130% load; 10s@105%~130% load	
Surge Capacity	2* rated power for 5 seconds	
Nominal DC Input Voltage	24Vdc	48Vdc
Cold Start Voltage	23.0Vdc	46.0Vdc
Low DC Warning Voltage @ load < 50%	23.0Vdc	46.0Vdc
@ load ≥ 50%	22.0Vdc	44.0Vdc
Low DC Warning Return Voltage @ load < 50%	23.5Vdc	47.0Vdc
@ load ≥ 50%	23.0Vdc	46.0Vdc
Low DC Cut-off Voltage @ load < 50%	21.5Vdc	43.0Vdc
@ load ≥ 50%	21.0Vdc	42.0Vdc
High DC Recovery Voltage	32Vdc	62Vdc
High DC Cut-off Voltage	33Vdc	63Vdc
No Load Power Consumption	<35W	<50W

Table 3 Charge Mode Specifications

Utility Charging Mode			
INVERTER MODEL	4KW	6KW	
Charging Algorithm	3-Step		
AC Charging Current (Max)	100A(@VI/P=230Vac)		
Bulk Charging Voltage	Flooded Battery	29.2Vdc	58.4Vdc
	AGM / Gel Battery	28.2Vdc	56.4Vdc
Floating Charging Voltage	27Vdc	54Vdc	
Charging Curve			
	MPPT Solar Charging Mode		
INVERTER MODEL	4KW	6KW	
Max. PV Array Power	5000W	7000W	
Nominal PV Voltage	320Vdc	360Vdc	
Start-up Voltage	70Vdc +/- 10Vdc		
PV Array MPPT Voltage Range	60-450Vdc		
MAX. PV Input Current	27A		
Max. PV Array Open Circuit Voltage	500Vdc		
Max Charging Current (AC charger + solar charger)	120A		

Table 4 General Specifications

INVERTER MODEL	4KW	6KW
Operating Temperature Range	-10°C ~ 50°C	
Storage temperature	-15°C~ 60°C	
Humidity	5% to 95% Relative Humidity (Non-condensing)	
Dimension (D*W*H), mm	125.3*302*466	
Net Weight, kg	9	10

7. INSTALLATION DIMENSION DRAWING

(unit: mm)

NOTE: The following picture is only a schematic diagram of the equipment .If the actual chassis does not conform to the schematic due to a structural upgrade, it is subject to prior notice.

